



Best Barns USA Assembly Book

Revised June 26, 2023



the Fairview

Building Size 12'x16'

Manufactured by RBS Holdings, LLC

205 Arlington Drive

Greenville, PA 16125

This manual is copyrighted. Under the copyright laws, this manual may not be copied, in whole or in part, without consent from

RBS Holdings, LLC

© Copyright 2022

IMPORTANT INFORMATION ABOUT YOUR KIT

Thank you for purchasing our kit. Please read the following information before beginning construction. Always check with your local HOA or building code office for any requirements or restrictions.

Floor: Wood flooring is sold optionally. You may choose to build your own or pour a cement pad.

Always wear safety glasses when cutting or nailing!

Tools Required:	Hand or Circular Saw	Level	Safety Glasses
	Cordless Drill	Measuring Tape	Dust Mask
	Hammer	6'-8' Ladder(s)	Phillips Screwdriver
	Pencil		Framing Square

Additional Materials - **Not included in kit:**

Windows are purchased separately

Required: Shingles or metal roofing, Drip Edge, Roofing Nails or Screws, Paint

Optional: Caulk, Ridge Vent

Terminology:

Square - Confirm corners are at 90 degrees

Plumb - Confirm walls and trusses are straight vertically

Wall Plate - Top and bottom 2x4s used to frame walls

Tie Plate - 2x4s connecting wall sections together

Header - Spans top of door opening

OSB - Oriented Strand Board

LAP - Edge of siding that overlaps Tongue

Tongue - Edge of siding that is overlapped

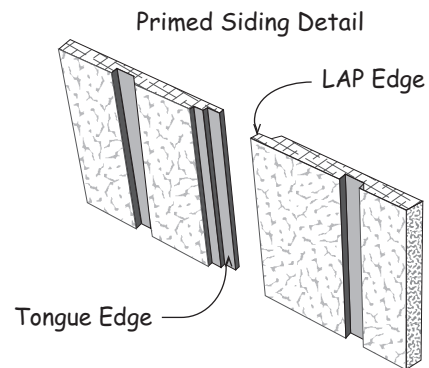

Organize:

Unpack all items & organize according to size and type. This will make items easier to find when instructed.

Review the parts list on the back page. Should there be missing items or sub-par material contact Best Barns Customer Service.

DO NOT discard any material including the pallet until your project is complete.

Assembly:

Review all instructions before you begin. Please follow steps carefully and in sequence for successful results.

If you have any questions we are happy to assist you. Please contact us at:

800-245-1577 - Mon - Fri 8AM - 5PM EST

724-866-4357 - After hours and weekends

Email - questions@barnkits.com

Typical Wood Floor System

Shown below is a typical wood floor. Depending on your area, the construction may have to be changed to meet local codes. When using a concrete slab, use the same overall foundation measurements. Install foam sill sealer as a moisture barrier between the concrete and the wall plates. Foam sill sealer can be purchased at home centers in rolls 3-1/2" or wider.

1. Cut (2) two 2x4 joist headers to 16' - 0". Layout for 16" on center joist spacing. 'X' marks where floor joist will be placed.

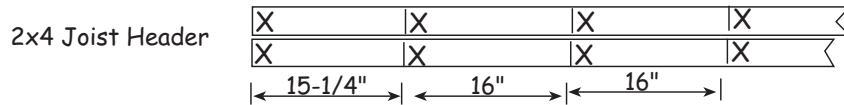

2. Cut 2x4-12' floor joist to 11'-9". Treated lumber may be thicker than 1-1/2". Take this into account when cutting the length of floor joists. Shorten joist measurements if necessary to obtain 12'-0" building width.

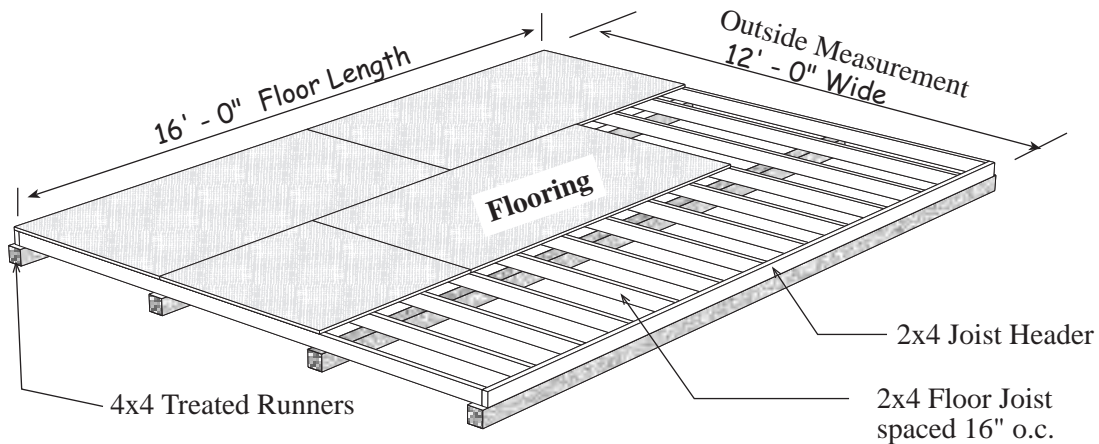

It is important that the floor be level and square. Square the floor as follows: before nailing the flooring, measure the floor diagonally (corner to corner). Then measure the opposite corners. These measurements will be the same if the floor is square.

Material Description	12' x 16' shed
2x4 Joist Headers	2 pcs. 16'
2x4 Floor Joist	13 pcs. 12'
4x4 Treated Runners	8 pcs. 8'
Flooring 5/8" or 3/4"	6 pcs. 4x8
Screw Floor Nails	2 lb. 8d
Galv. Box Nails	2 lb. 16d

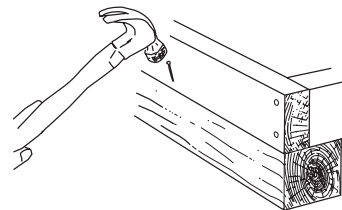

Nail 2x4 joist headers and floor joist to 4x4.

 **Do not discard any material until construction is complete. Including short blocks of 2x4s.**

Step 1 Assemble 12' Long Back wall

1. Gather (4) four 2x4-72" boards and position together then indicate with 'X' marks, where the wall studs will be located. Mark the ends that will butt together with 'the letters A' and 'B'.

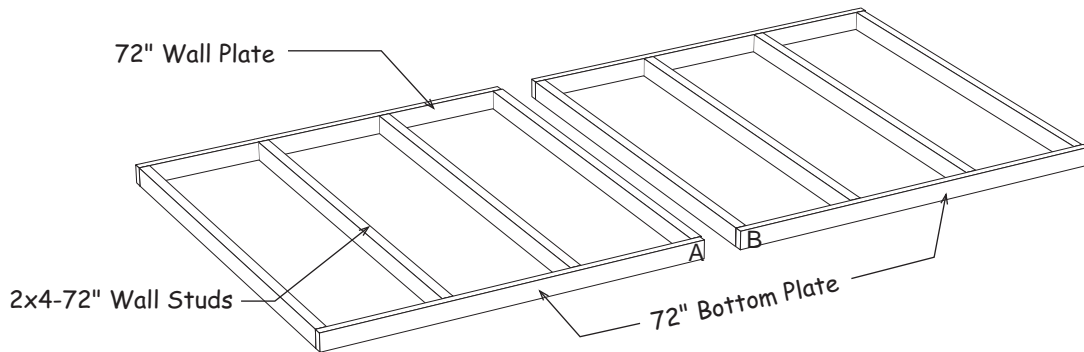
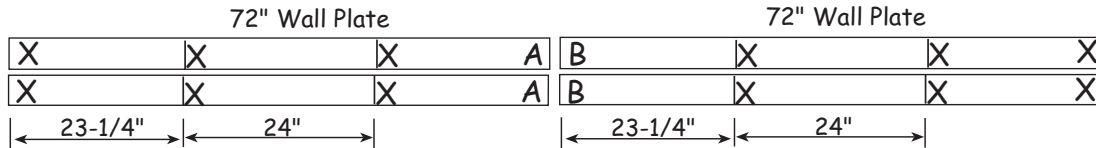

2. Install (8) eight 72" wall studs between the top and bottom plates. Use 10d sinkers, two (2) nails at each stud end. Nail both wall frames together with 10d sinkers.
3. Square wall frame. *Measure diagonally (corner to corner). The measurements will be the same when the wall is square.*
4. Install the first siding panel with the 'LAP edge' flush the end of the wall and extending 3/4" below the bottom plate. Use 6d galv. nails spaced 8" apart.
5. Install (2) two more siding panels.

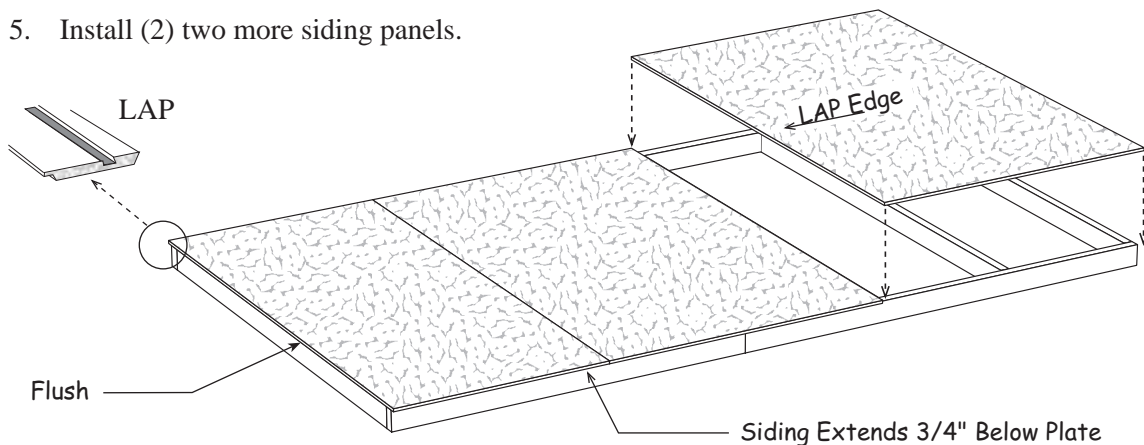

Step 2 Assemble 116-1/2" Long Sidewall - No Doors

1. Position (2) two 68-1/2" and (2) two 48" long 2x4 boards together and indicate with 'X' marks, where the wall studs will be located. Mark the ends that will butt together with the letters 'A' and 'B'.

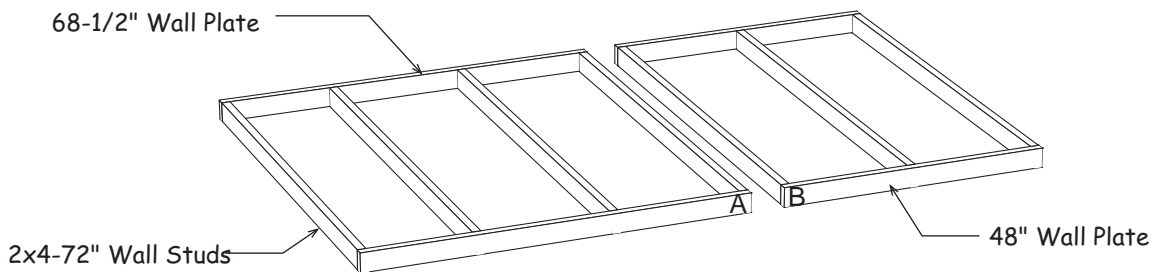
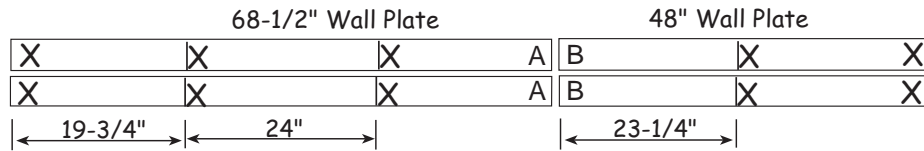

2. Install (7) seven 72" wall studs between the top and bottom plates. Assemble wall frames with 10d sinkers, (2) two nails at each stud end. Nail both wall frames together.
3. Square wall frame.
4. Cut a full width siding panel in half lengthways. Select the cutoff with the 'Tongue' edge. Install this siding panel with the cut edge extending 3-1/2" past the wall frame. The bottom will extend 3/4" below the bottom plate.
5. Install two (2) full width siding panels.

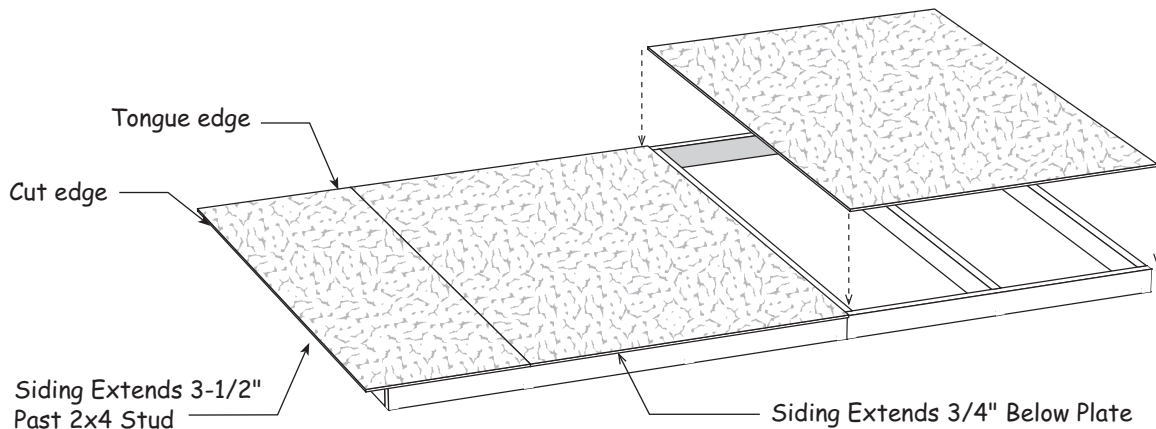

Step 3 Assemble 68-1/2" Long Sidewall - No Doors

1. Position (2) two 68-1/2" long 2x4 boards together and indicate with 'X' marks, where the wall studs will be located.

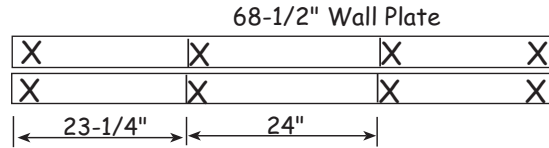

2. Install (4) four 72" wall studs between the top and bottom plates.

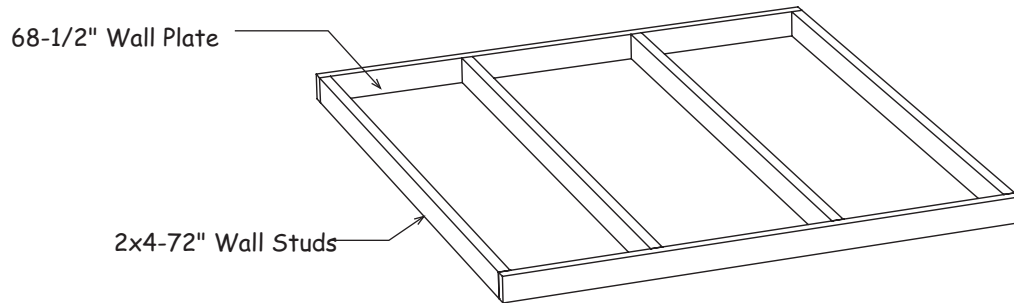

3. Select the 116-1/2" sidewall assembled in **Step 2**. Butt the wall frame, *assembled above*, against the wall with siding. **DO NOT** nail these frames together so they can be separated later.
4. Install a full width siding panel but do not nail along the long edge that overlaps the 116-1/2" wall frame. You can nail this edge after the wall panels are installed. This will enable you to separate the wall panels making them easier to handle.
5. Install the 24" siding panel, cut in **Step 2**, last. It will extend 3-1/2" beyond the wall frame.

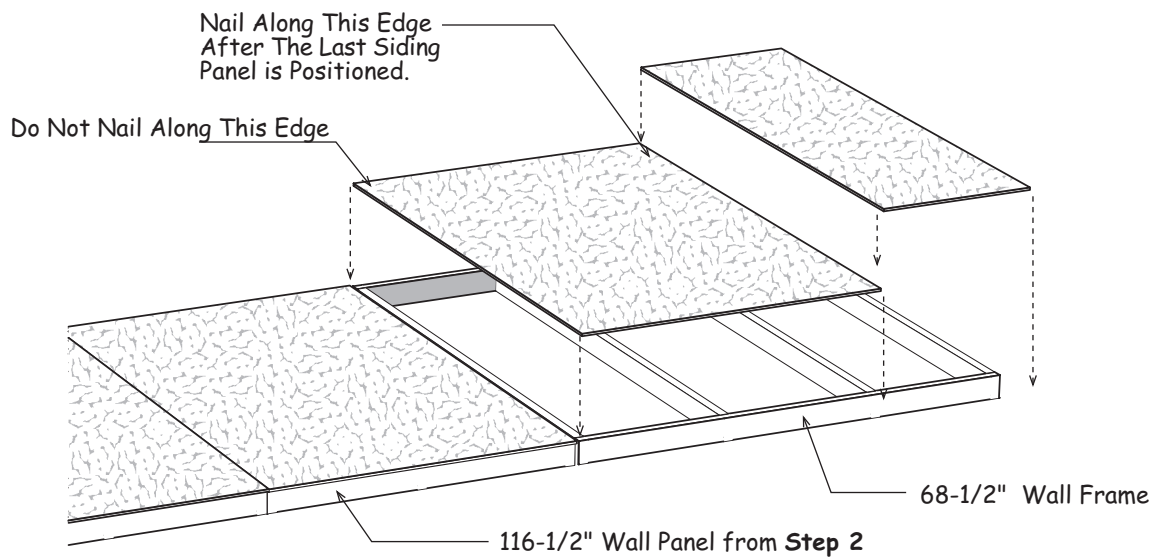

Step 4 Assemble (2) Two Front Wall Frames

1. Cut (2) two 58-1/2" long 2x4s to 56-1/4". Position them together and indicate with 'X' marks where studs will be located.

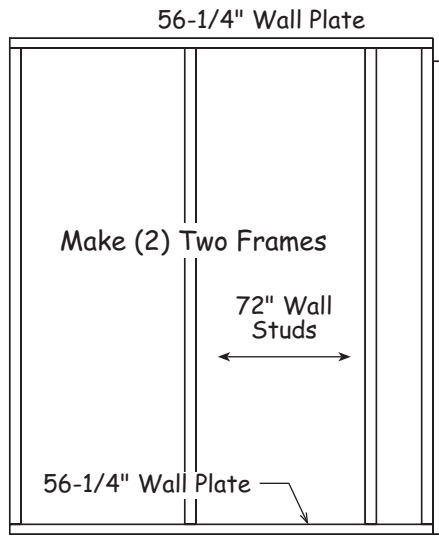
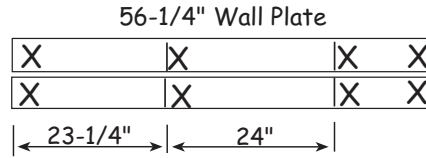

2. Install (4) four 72" wall studs between the wall plates.
3. Locate (1) one 2x4-72" and cut to 71-1/2". Install as a header support on right side as shown and flush with bottom plate. Use 10d sinkers.
4. Locate (2) two 2x4-72" boards and cut each to 56-1/4".
5. Repeat steps 2-3 to assemble another wall frame.

Step 5 Apply Siding to Left Front Wall Frame

1. Select one of the wall frames from **Step 4**. Position frame with the header support on the right. Install a full width siding panel with the 'LAP' edge flush with the end of the wall frame.
2. Install a 9-3/4" wide siding panel with a 'LAP' edge. The cut edge should be flush with header support.

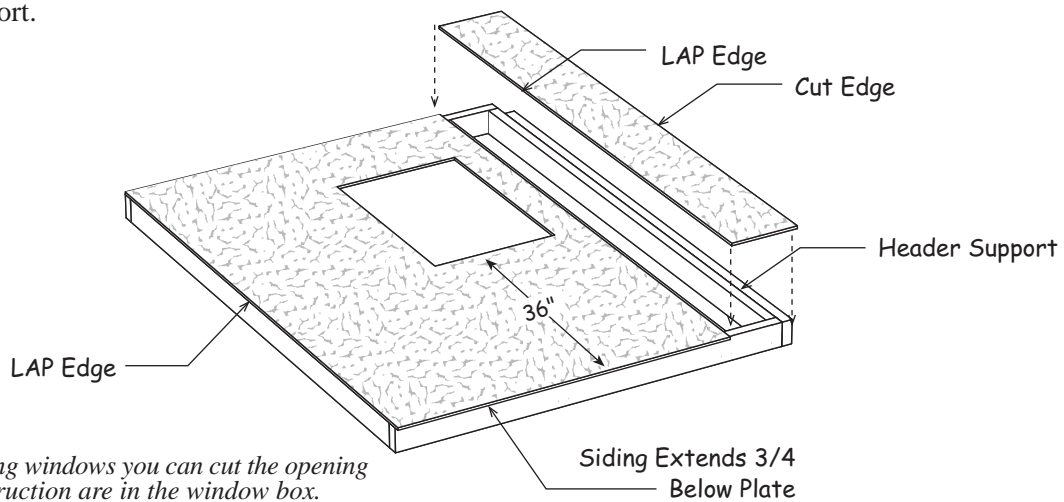

If installing windows you can cut the opening now. Instruction are in the window box.

Step 6 Apply Siding to Right Front Wall Frame

1. Select the remaining wall frame. Position wall frame with the header support on the left.
2. Install a 9-3/4" wide panel with a 'Tongue' edge. Install with the 'cut' edge flush with the 2x4 header support.
3. Install a full width siding panel. Cut siding flush with end of frame if necessary.

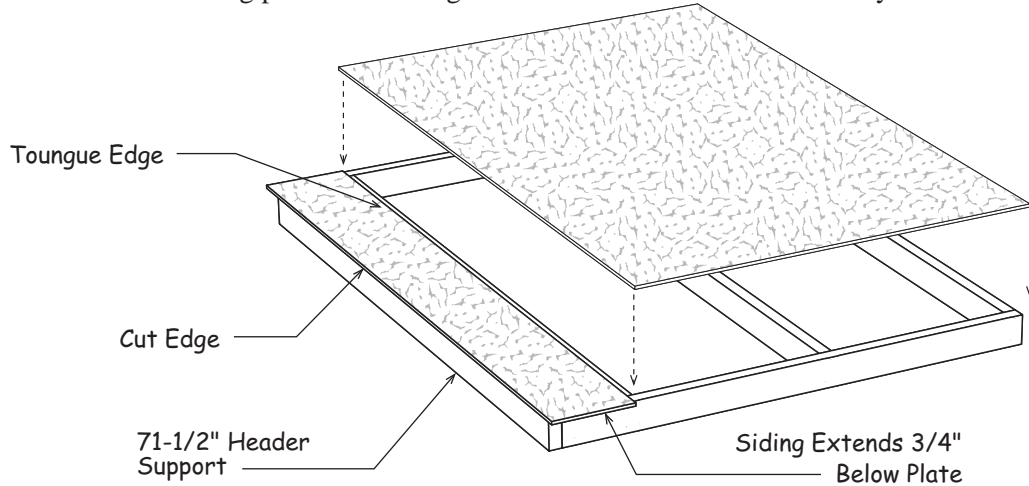

Step 7 Assemble Door Headers

1. Gather (2) two 31-1/2" long 2x4 boards and 3-1/4" x 31-1/4" OSB filler panel. Nail header together from both sides with 10d sinkers staggered 6" apart.

 This material is packed in door carton.

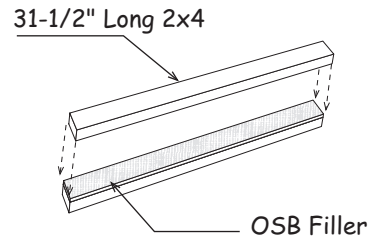

2. Gather (2) two 67-1/2" long 2x4 boards and a 3-1/4" x 67-1/4" OSB filler panel. Glue both sides of OSB. Nail header together from both sides with 10d sinkers staggered 6" apart.

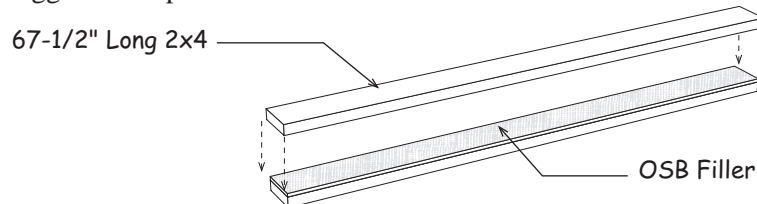



Complete this step if you want the double doors centered on the sidewall. If you want the doors to be offset, set front cover, skip to **Step 9**.

Step 8 Assemble Sidewalls - Double Doors Centered

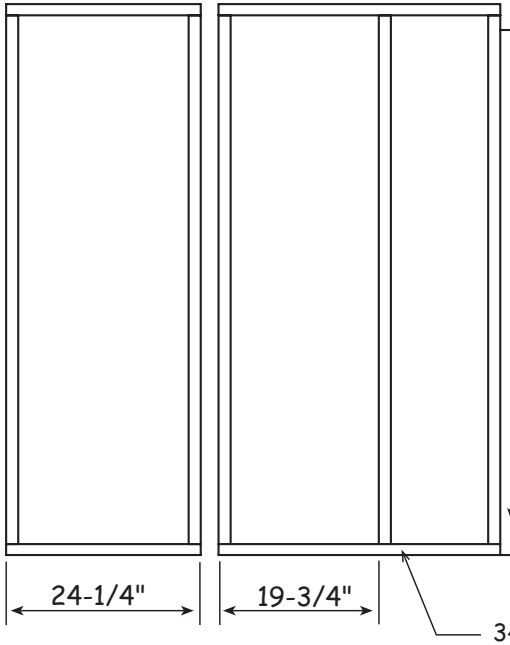

1. Locate (2) two 2x4-48" boards. Cut these boards to a length of 24-1/4".
2. Assemble a 2' wall frame with the plates cut above and (2) two wall studs. Use 10d sinkers.
3. Locate (2) two 34-3/4" long 2x4s and position them together. Indicate with 'X' marks where studs will be located..

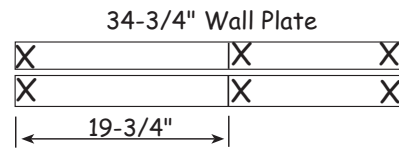

4. Install (3) three 72" wall studs between 34-3/4" wall plates.
5. Locate (1) one 2x4-72" and cut to 71-1/2". Install as a header support on right side as shown and flush with bottom plate. Use 10d sinkers.

6. Butt the 24-1/4" frame to the 34-3/4" frame on opposite side of header support. Nail frames together with 10d sinkers.
7. Locate a 16" wide siding panel that has a 'LAP' edge. Position this panel with the cut edge flush with the 2x4 header support and extending 3/4" below the bottom plate. Do not nail along the LAP edge until the other siding panel is installed.
8. Install a full width panel. The 'LAP' edge will extend 3-1/2" beyond the end of the frame. The siding should extend 3/4" below the bottom plate.

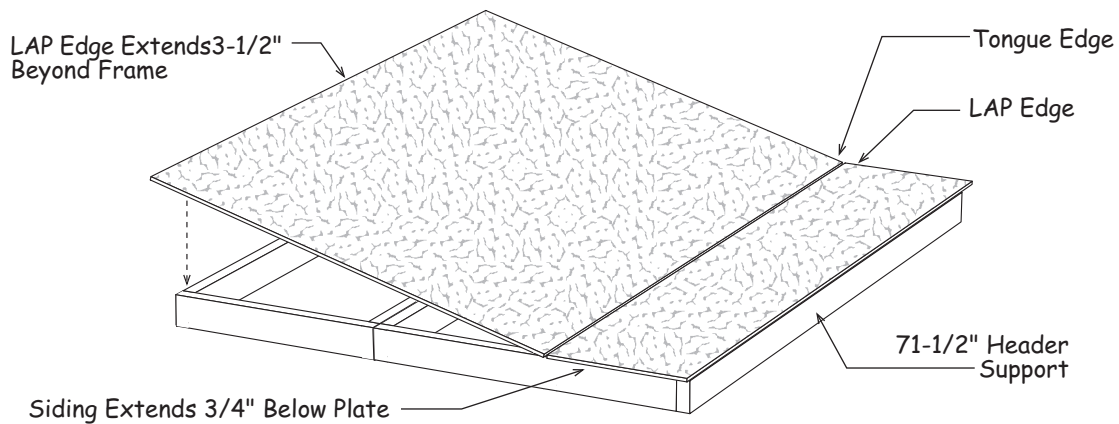

Step 8 Assemble Sidewalls - Double Doors (continued)

1. Located (2) two 58-1/2" long 2x4s and position them together. Indicate with 'X' marks where studs will be located.

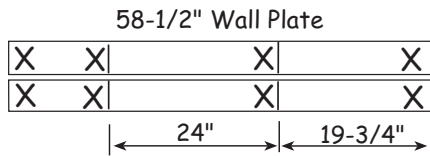

2. Install (4) four 72" wall studs between 58-1/2" plates. Use 10d sinkers.
3. Locate (1) one 2x4-72" and cut to 71-1/2". Install as a header support on left side as shown and flush with bottom plate. Use 10d sinkers.

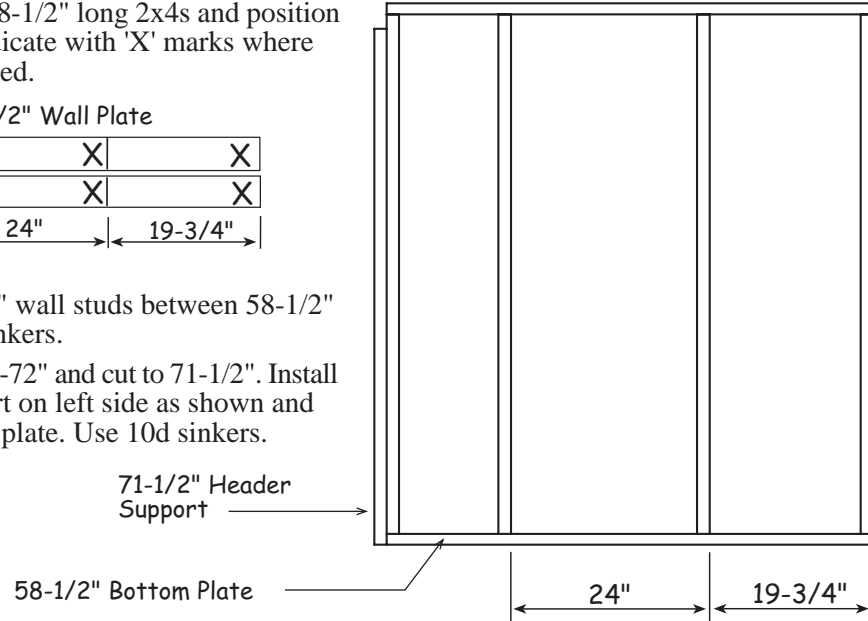

4. Install a 16" siding panel with the cut edge flush with the side of the door opening.
5. Install a full width siding panel. The siding will extend 3-1/2" beyond the frame.

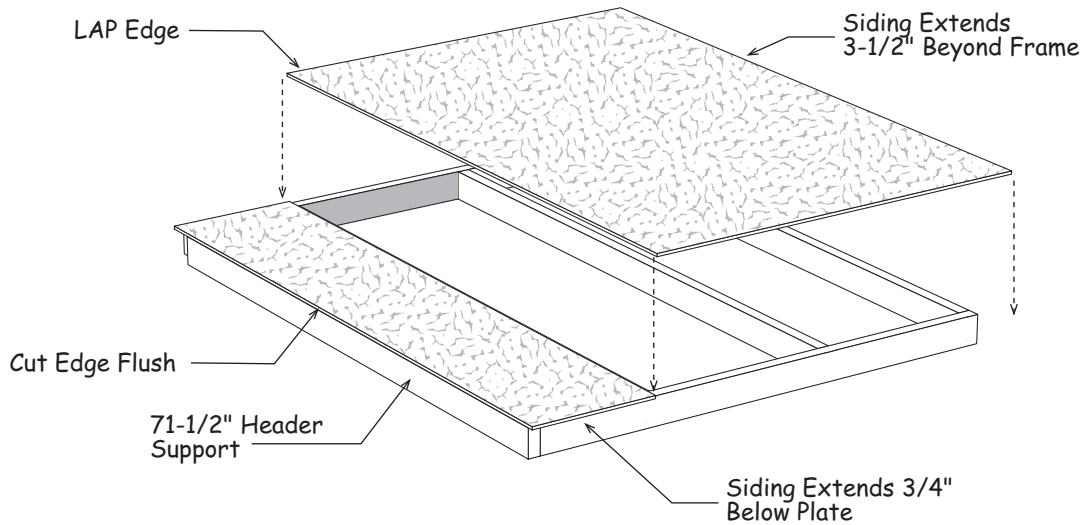

Skip to Step 10.

Step 9 Assemble Sidewalls - Double Doors Offset

1. Locate (1) one 34-3/4" long board and cut (2) two boards 11" plates from this board.
2. Install (2) two 72" wall studs between 11" wall plates. See layout below. Use 10d sinkers.
3. Position (2) two 48" long 2x4s together and indicate with 'X' marks where wall studs will be located.
4. Install (4) four 72" wall studs between 48" wall plates.
5. Locate (2) two 72" long 2x4s and cut each to 71-1/2". Install these as a header support on each wall frame flush with bottom plate. Use 10d sinkers.

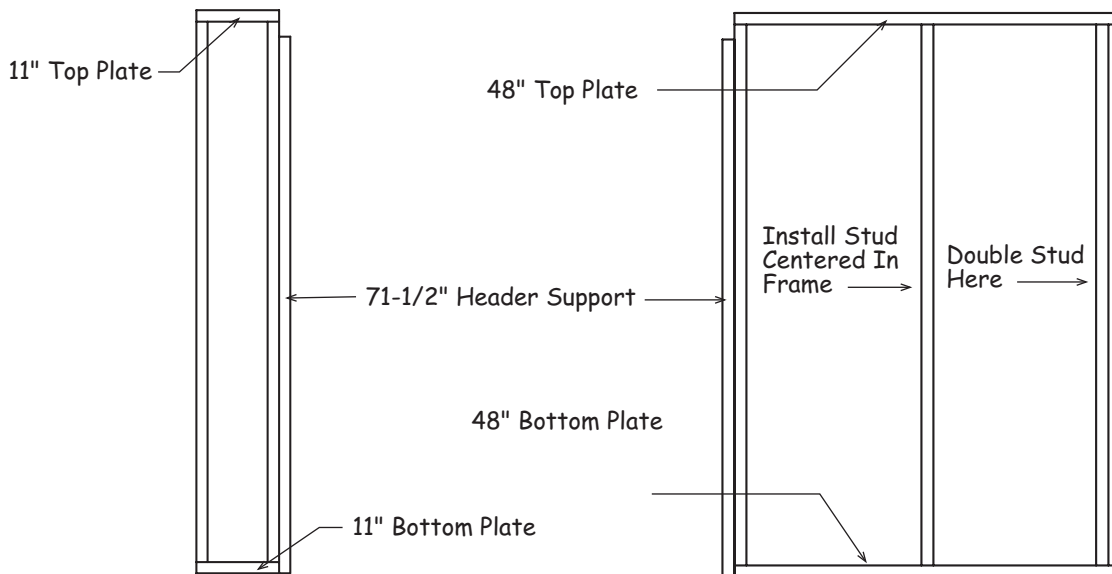

6. Position (2) two 58-1/2" long 2x4s together and indicate with 'X' marks where wall studs will be located. Mark the right most stud location with 'R'.

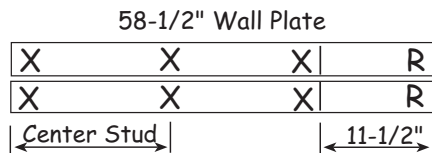

7. Install (4) four 72" wall studs between 58-1/2" plates.

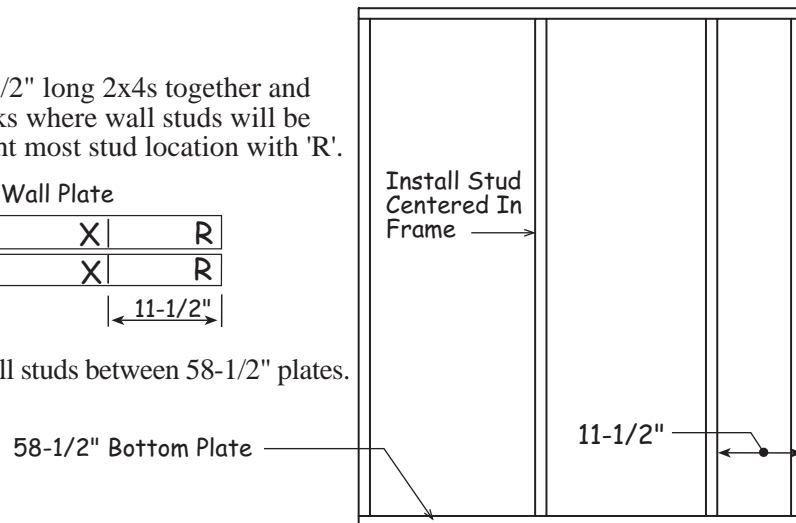

Step 9 Assemble Sidewalls - Double Doors (continued)

1. Select the 12-1/2" wide wall frame. Install a 16" siding panel with the tongue edge flush with the side of the header support.

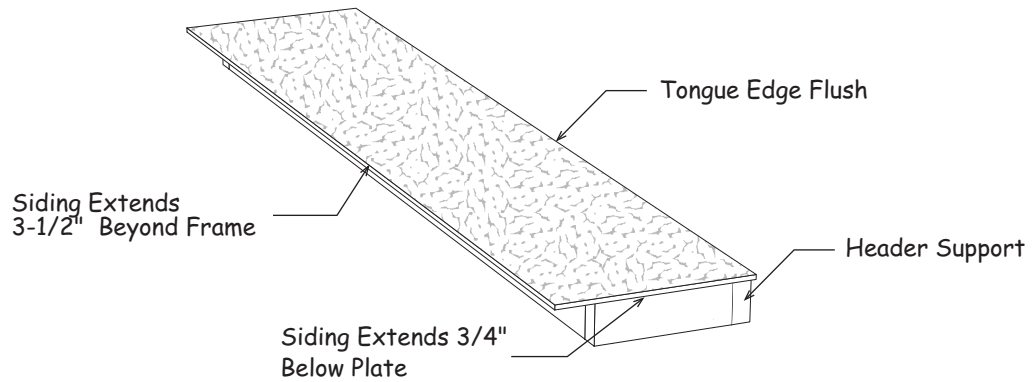

2. Select the 48" wide wall frame. Position header support on the left and butt the right side against the 58-1/2" wall frame. Insure the 'R' is on right. Nail together using 10d sinkers.
3. Install (2) two 48" wide siding panels. Install the first panel with the 'LAP' edge flush with the 71-1/2" long header support. If you are installing an optional window, you can cut out the window opening now or later.
4. Install a 16" wide siding panel. The siding will extend 3-1/2" beyond the frame.

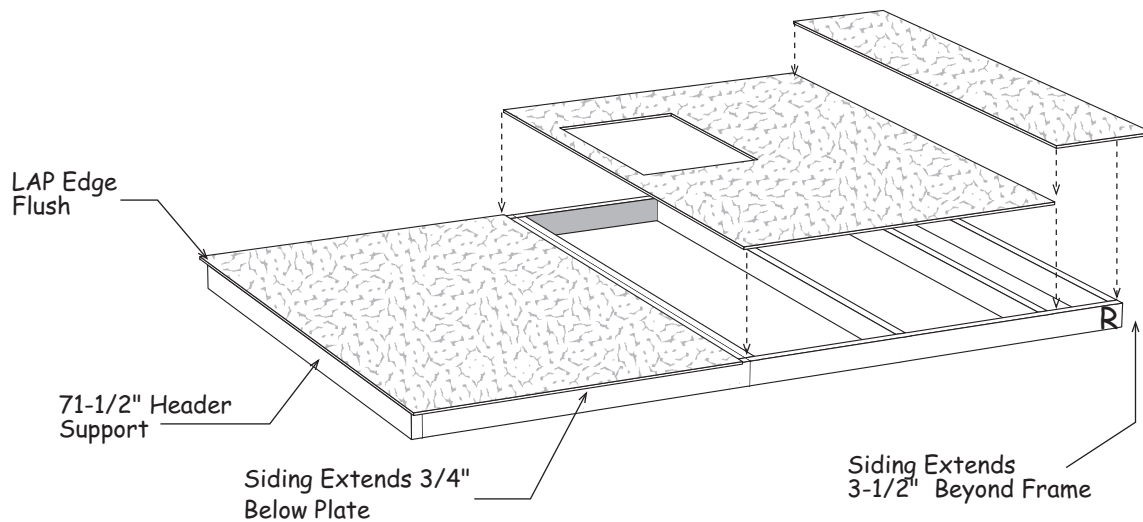

Step 10 Assemble Roof Gables

1. Butt (2) two 72" long 2x4s together and secure them with a 3-1/2" x 31-3/4" long plywood gusset across the top where they butt together. Use glue and (12) twelve 6d common nails. This will be used as the bottom plate on the roof gables.
2. Repeat to assemble another 12' long bottom plate.

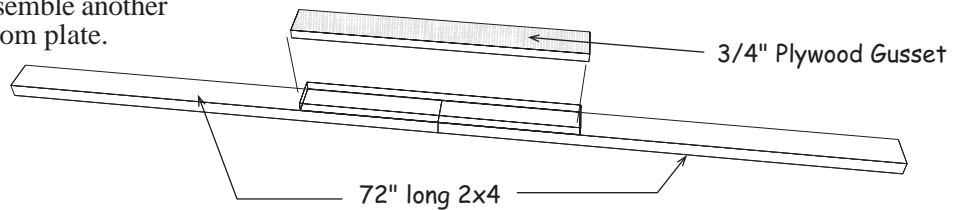

3. Place the bottom gable plate on the floor along with (2) two 80-1/2" long 2x4 truss rafters as shown below. Bottom plate will be on edge. There are short 2x4s, *that may have an angle on one end*, supplied in the kit. Use these to hold the truss rafter and bottom gable plate together by temporarily screwing the blocks to the floor using 2-1/2" screws. This will ensure that the gable frames and the trusses, *assembled next*, are identical.
4. Secure the top of the truss rafters together with a 1"x4" barbed metal drive-on plate.
5. Install (2) two 23-1/2" gable studs with angle cut at one end. Nail through the bottom plate with 10d sinkers and secure the top with barbed metal drive-on plates.

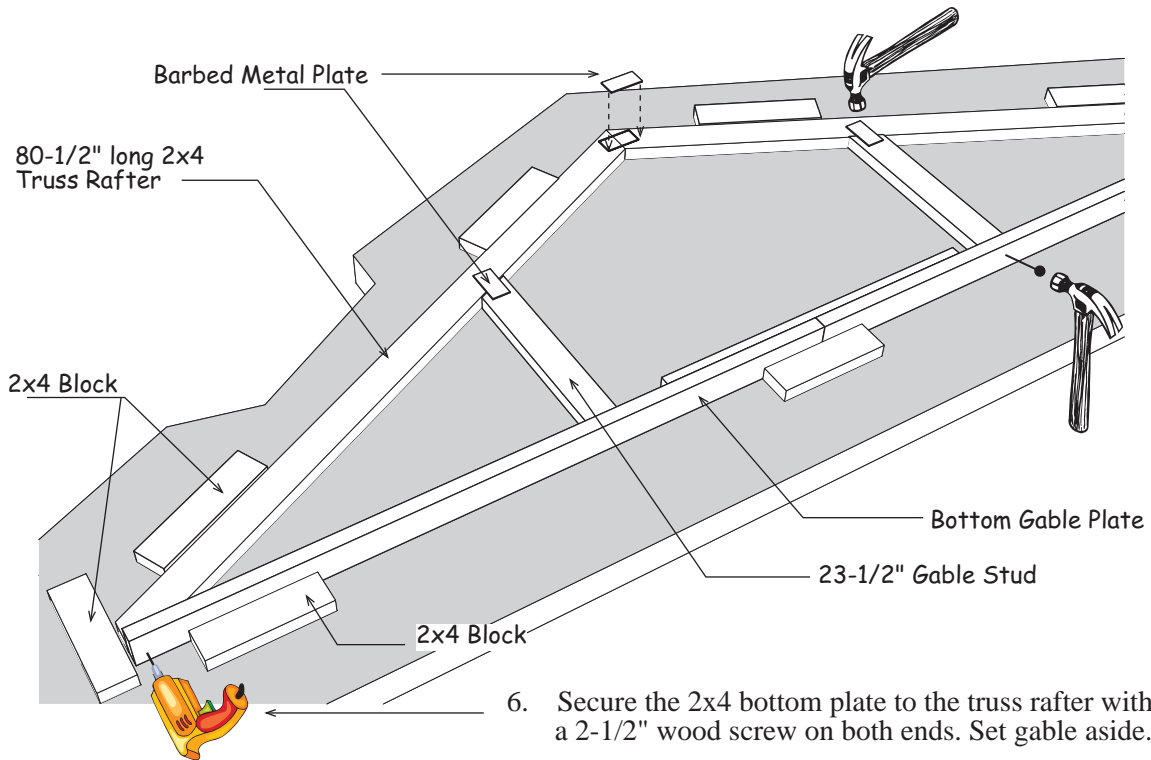

6. Secure the 2x4 bottom plate to the truss rafter with a 2-1/2" wood screw on both ends. Set gable aside.
7. Repeat steps 3-6 to assemble another gable.

Step 11 Assemble Roof Trusses

1. Place (2) two 80-1/2" long 2x4 truss rafters and a 82" long collar tie together as shown below. The collar tie has an angle cut on both ends. Reposition the lower 2x4 blocks to hold the truss rafters in place. See **'Detail B'**.
2. Secure the 2x4 truss rafters at the top with a 8" x 16" wood gusset. Apply wood glue between the 2x4s and the gusset. Nail the gusset to the 2x4s with (14) fourteen 6d common nails,
3. Secure the 2x4 collar tie with (4) four 2-1/2" long wood screws at each end. Tip: Pre-drill holes with an 1/8" bit to prevent wood splitting at ends.
4. Turn this truss over and apply a wood gusset to the opposite side at the ridge.
5. Repeat to assemble (6) six more trusses.

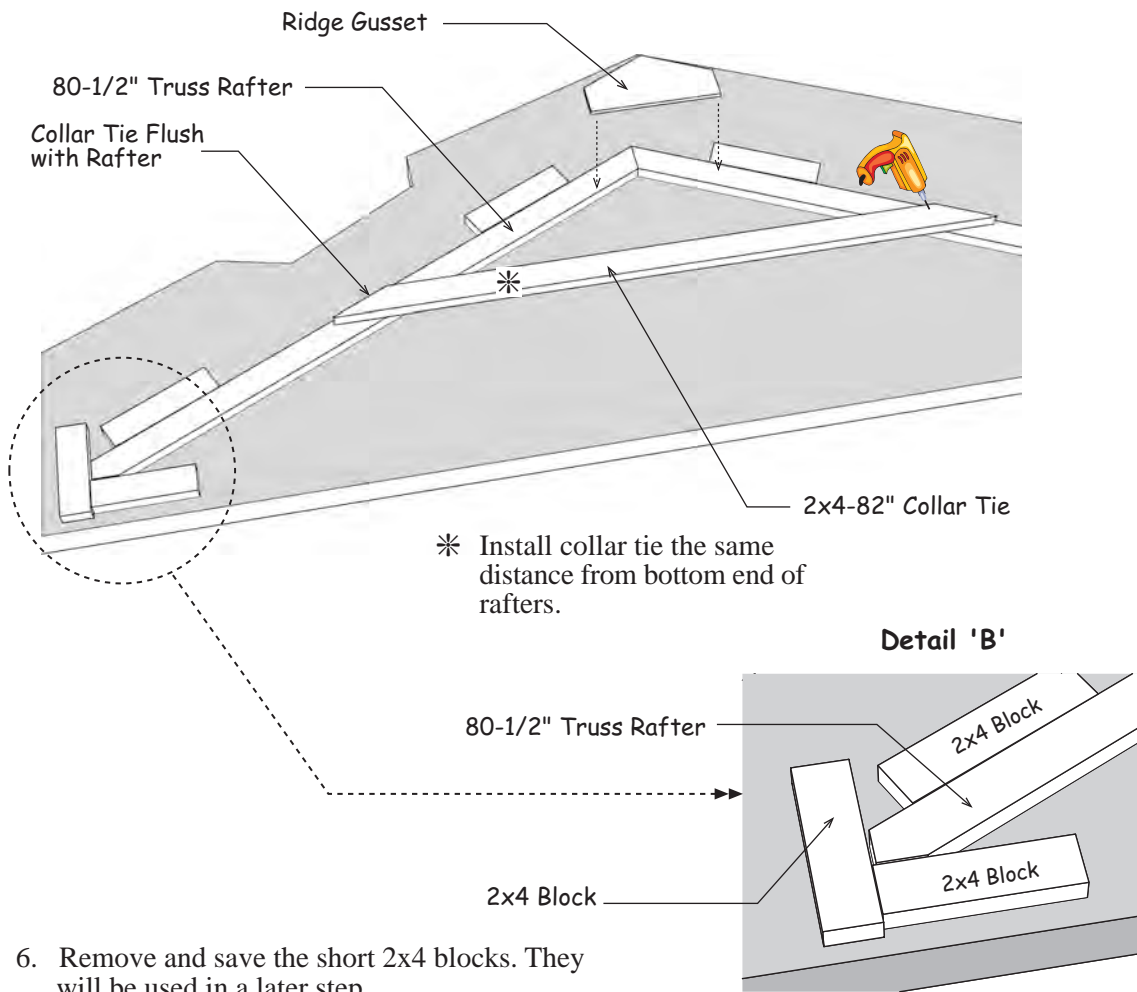

Step 12A Set Walls Panels-Doors Centered on Sidewall



The detail below indicates how the walls will be set when the double doors are located in the center of the sidewall. For offset double doors refer to Step 12B.

1. Erect wall panels. **IMPORTANT** make sure walls are plumb and square. Secure wall panels together at the corners. Use (4) four 10d coated nails per corner.
2. Nail along siding edge where it overlaps at corners. Nail through the bottom plate. Space 10d sinkers 24" apart.
3. Install the 67-1/2" door header between the sidewall panels. Nail through the wall stud into the ends of the header. Toenail into the top wall plates.
4. Install the 31-1/2" door header between the front wall panels.
5. Temporarily install (2) two 2x4-72" boards at both sides of the door opening to hold the wall straight. These boards will be used later for tie plates.

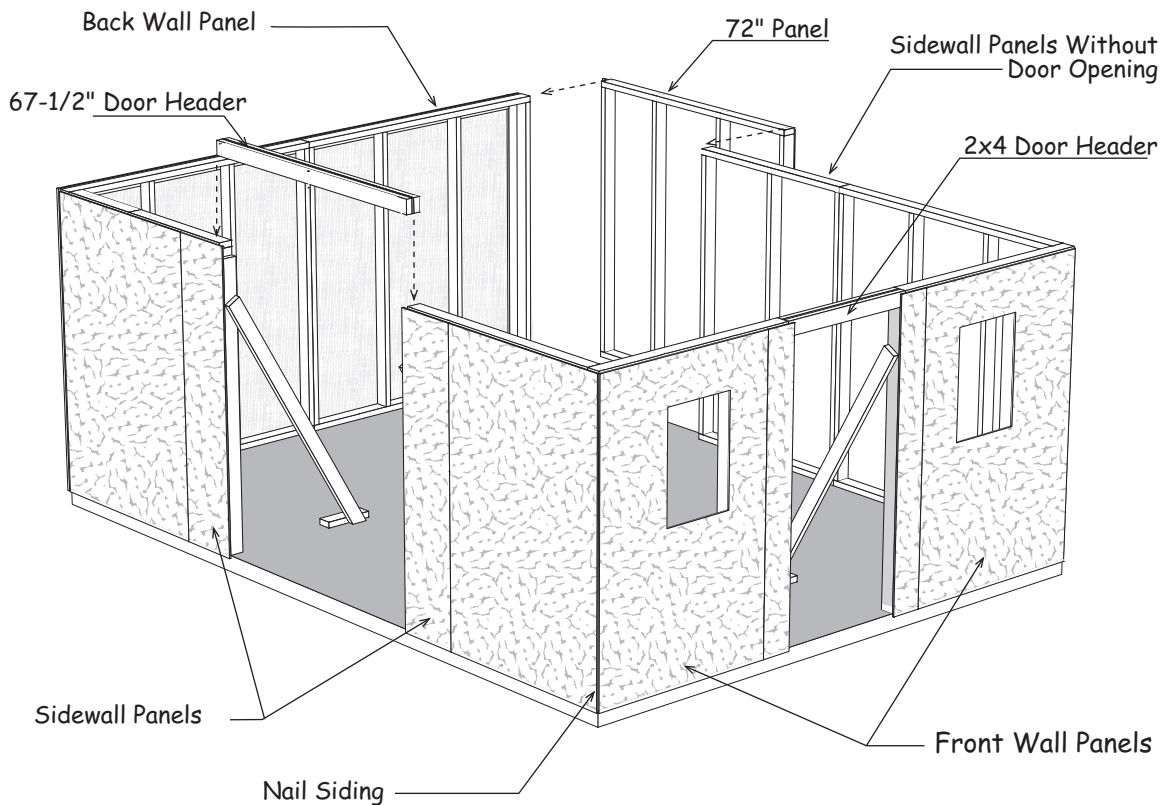

Step 12B Set Walls Panels-Doors Offset on Sidewall

1. Erect wall panels. **IMPORTANT make sure walls are plumb and square.** Secure wall panels together at the corners. Use (4) four 10d coated nails per corner.
2. Nail along siding edge where it overlaps at corners. Nail through the bottom plate. Space 10d sinkers 24" apart.
3. Install the 67-1/2" door header between the sidewall panels. Nail through the wall stud into the ends of the header. Toenail into the top wall plates.
4. Install the 31-1/2" door header between the front wall panels.
5. Temporarily install (2) two 2x4-72" boards at both sides of the door opening to hold the wall straight. These boards will be used later for tie plates.

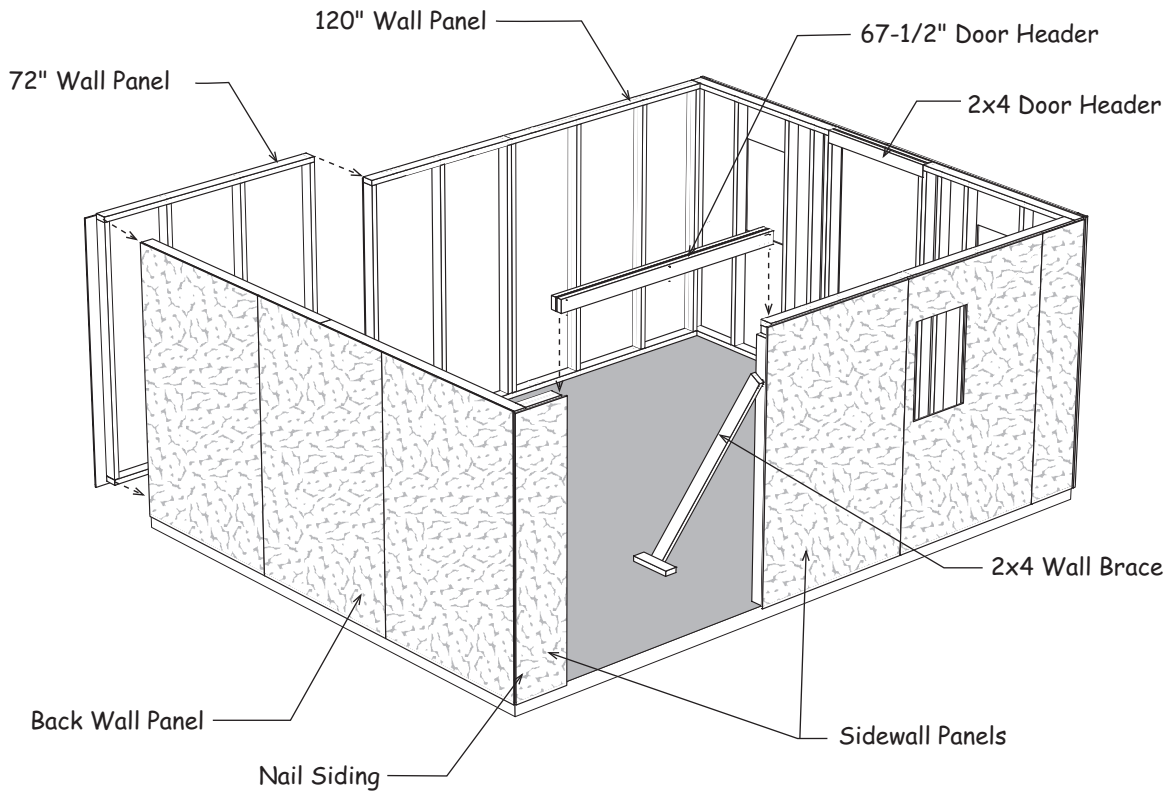

Step 13 Install Siding on Door Headers

1. Install (2) two 4-1/4" siding panels over the door header on the side wall. The siding should extend 3/4" below the door header. Wall trim, installed later, will hide where the siding butts the front wall siding.
2. Install (1) one 4-1/4" siding panel over single door. Cut panel to fit. Siding should extend 3/4" below door header.

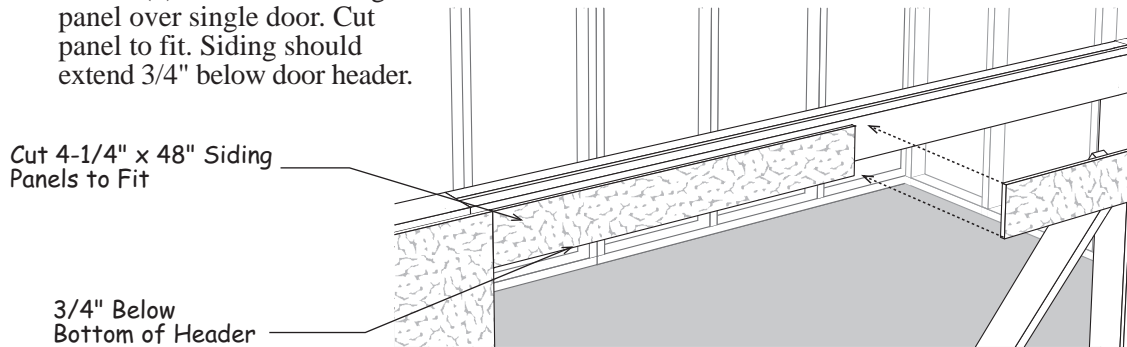

Step 14 Install 12' Side Wall and Door Trim

 *Tip; Paint the siding and trim boards before installing the trim.*

1. Install (2) two 75-3/4" long 1x3 corner trim boards to the side wall flush with the top 2x4 wall plate and flush with siding on the front and back walls. Use 6d galv. nails spaced 12" apart.
2. Repeat on opposite side wall.
3. Install a 1x3-72" trim board centered across the top door opening flush with top of siding. The header siding will extend below this trim board.
4. Locate (2) two 1x3-72" boards. Tack these, *with a couple nails*, flush to each side of the door opening and against bottom of upper trim.

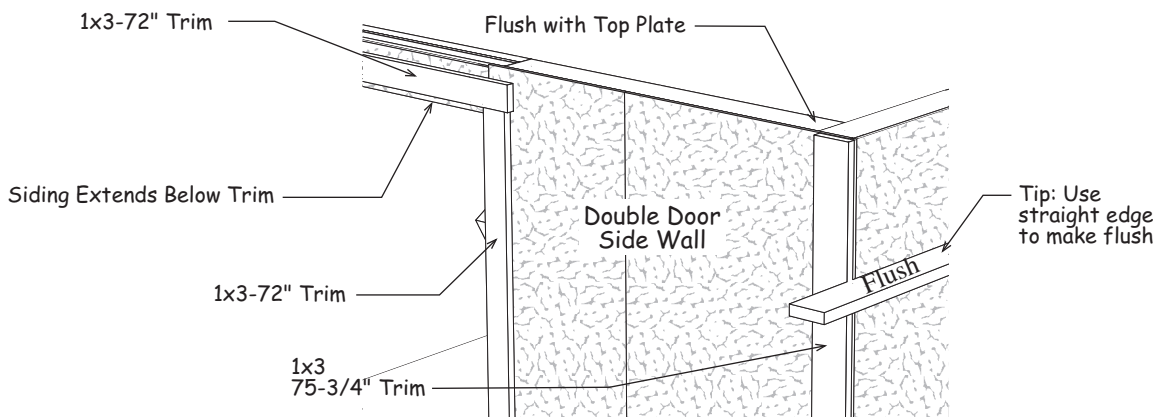

Step 15 Install Trim

1. Install a 75-3/4" long 1x4 trim board to the front wall flush with wall plate and with 1x3 trim.
2. Butt a 1x4-6' trim board against 1x4 corner trim and flush with top plate. Nail along top edge.
3. Cut a second 1x4-6' trim board to finish at opposite corner.
4. Repeat to install trim on back wall and opposite side wall.

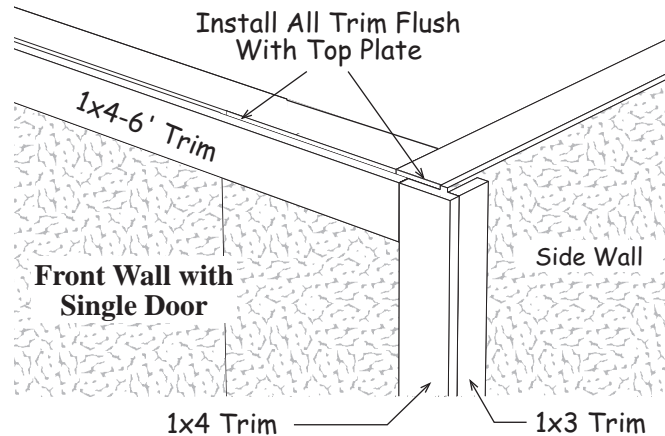

Step 16 Install Primed Soffit

1. Locate (1) one 7" wide x 48-3/4" long siding panel and cut in half. Install one half over the side wall with the primed side facing down. Cut edges should be flush with the inside of the top 2x4 wall plate and flush with the trim on the front wall. Tack the soffit with a couple 6d common nails. Installing 2x4 tie plates in a later step will provide more nailing.
2. Install (4) four more soffit boards cutting the last soffit flush with the back wall trim.
3. Repeat to install 7" soffit boards on the opposite side wall.
4. Install (3) three 4-1/4" wide x 48-3/4" filler panels over the front wall. Install the filler flush with the 1x4 trim. Cut last filler to fit.

Soffit and Filler Flush with Front Wall Trim

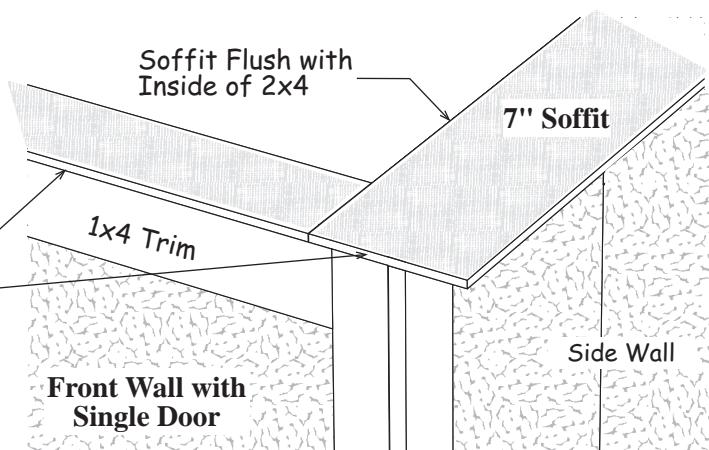

5. Repeat to install filler on the opposite wall.

Step 17 Install Siding on Gables

1. Select one of the gable frames. Turn the gable over so bottom plate is on edge on floor. Support gable studs and rafters with (2) two 2x4-72" boards stacked. This will give you a solid surface when nailing siding.
2. Install left gable siding panel with the 'LAP' edge flush with the end of of bottom plate. Use 6d galv. nails across the top of the 2x4 frame and gable studs. Use 6d galv. nails across the bottom plate. The siding will extend 3/4" below the bottom 2x4.
3. Install center and right panels. Cut last panel flush with end of bottom plate.
4. Repeat to install siding on the other gable frame.

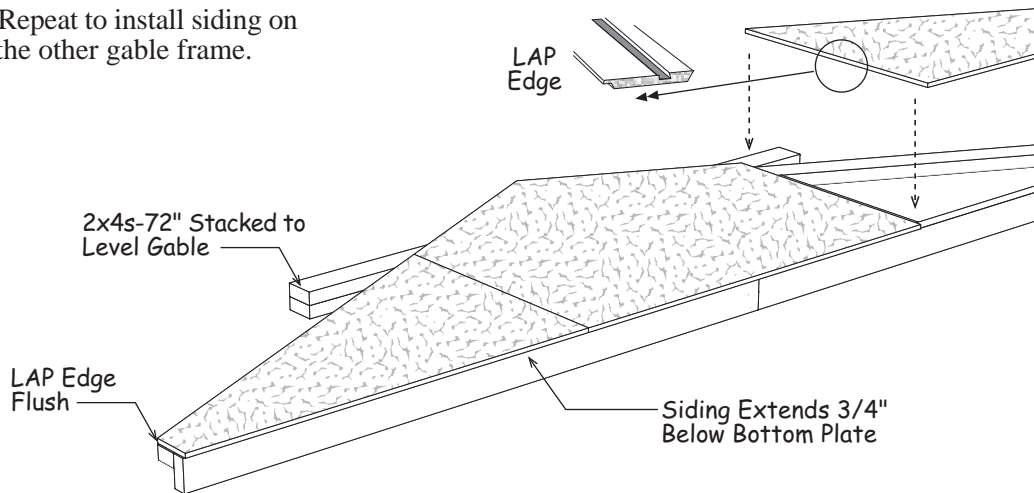

Step 18 Install Gables

1. Install a gable on the rear wall. The gable siding will extend over the 1x4 trim on the lower wall. Secure gable to wall by nailing through the gable plate with 10d sinkers. Nail siding along the 1x4 trim board with 6d galv. nails.
2. Install gable on the front wall.

Important: Bottom edge of siding extends over 1x4 trim. Paint this edge.

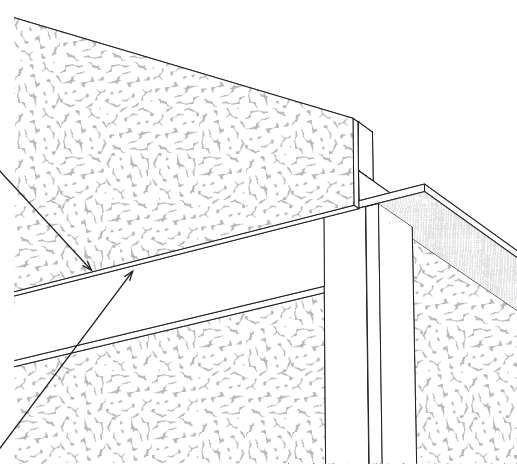

Step 19 Install 2x4 Tie Plates

1. Install (2) two 72" long 2x4s over the soffit panels on the side wall. Install the 2x4s flush with the inside of the side wall. Use 10d sinkers.
2. Cut to fit 48" long 2x4 and butt against gable to finish.
3. Repeat process to install 2x4 tie plates on the opposite wall.

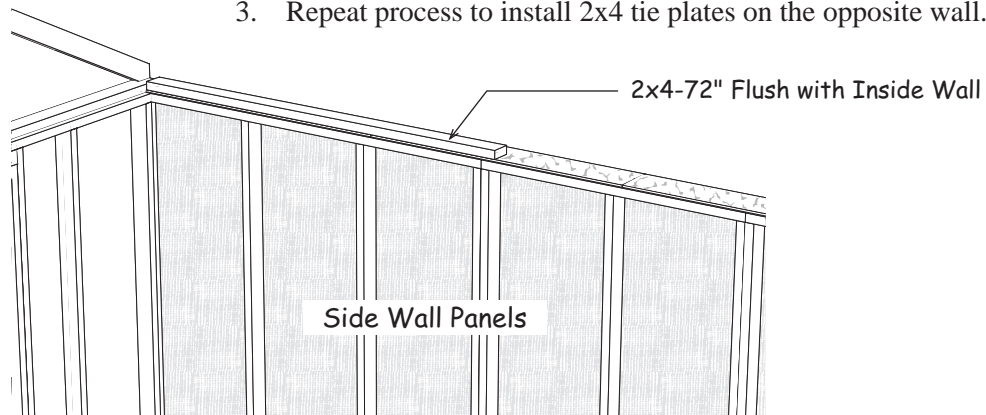

Step 20 Layout Roof Trusses

1. Layout the truss spacing from the rear wall of the building. Measure from the backside of the 2x4 gable frame when marking the location of the first truss. Continue 24" spacing to other gable. **Important:** When marking the opposite wall, place the 'X' mark on the same side of the line so your trusses are parallel when they are installed.
2. Install metal hangers to the tie plate with hanger nails. The opening should line up with the 'X' mark, the bottom of the opening, flush with the 2x4 tie plate. **Detail 'D'**.

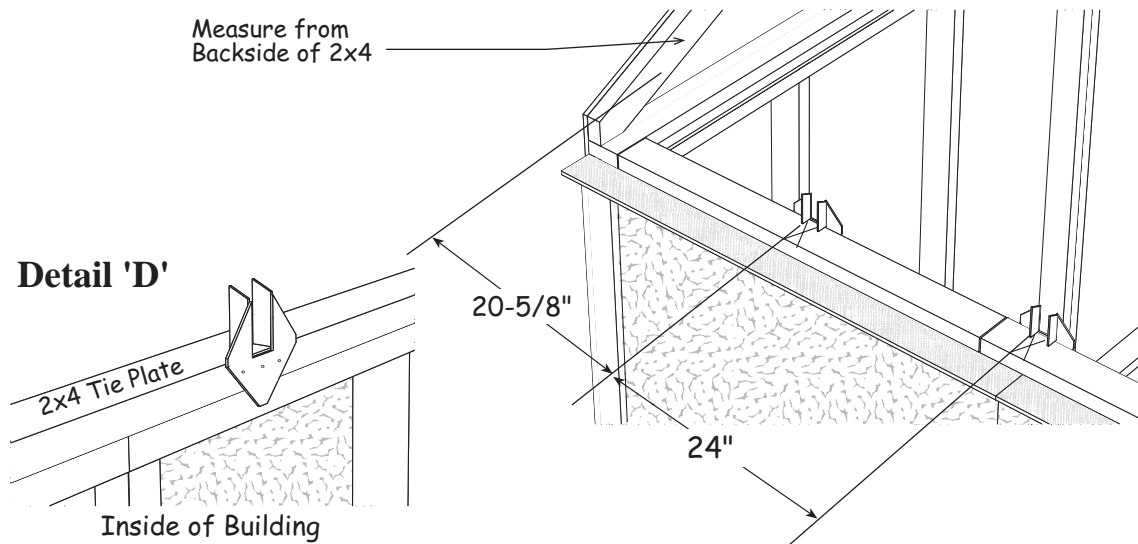

Step 21 Set Roof Trusses and Soffit Blocks

1. Set roof trusses. Secure trusses to metal hangers with hanger nails.
2. Install short 2x4 blocks in front of each truss. Secure 2x4 blocks to the soffit panel using (2) two 1-1/2" long exterior screws.
3. Install a 2x4 block at each end of the soffit, flush with the 2x4 gable frame. Not siding.

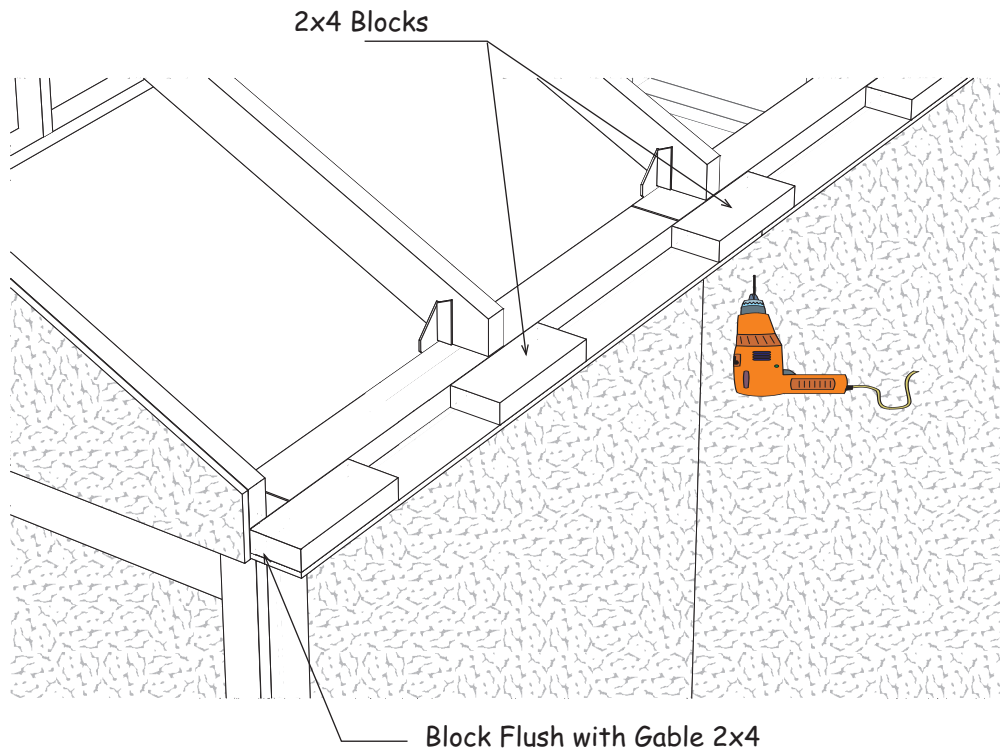

Step 22 Install Siding Filler

Install small primed siding fillers, *packed with the hardware*, over the 2x4 soffit blocks. Siding fillers will be flush with the gable siding. Use 6d galv. nails.

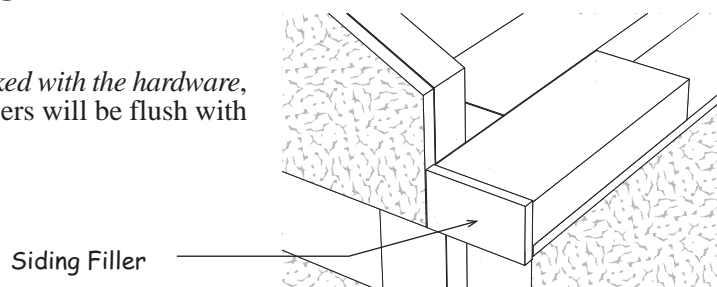

Step 23 Install Rear Gable Trim

1. Install a 8-1/2" long trim board, *called a keystone*, at the top of the gable flush with the top of the gable frame. Use 6d galv. nails.
2. Install (2) two 81" long 1x4 trim boards flush with the top of the gable frame. Use 6d galv. nails.

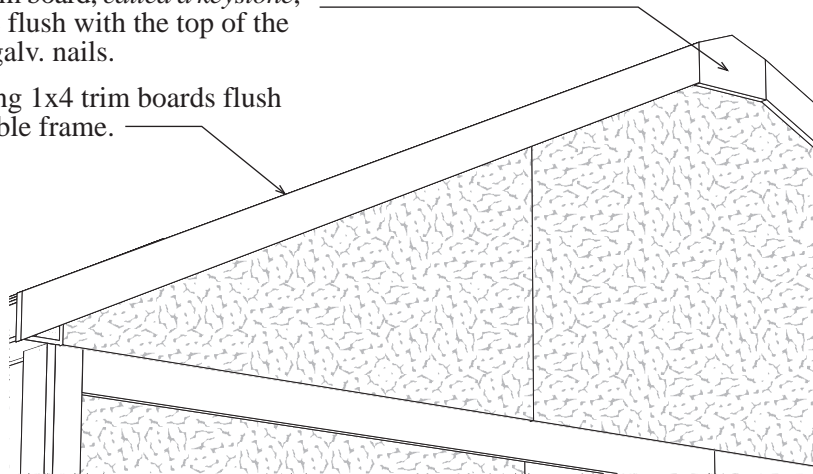

Step 24 Install 1x4 Fascia

1. Starting at the rear of the building, install a 1x4-6' fascia board against the rear gable trim. Install the fascia so the bottom edge of the roof sheathing will rest on the edge of the 1x4. **See Detail 'E'**. Use a straight edge to align the 1x4 board with the top of the trusses. Nail to each soffit block using (2) two 6d galv. nails each.
2. Install a 1x4-4' white pine fascia board next.
3. Do not install a fascia board on the front end of building. This is installed later.
4. Repeat on opposite side wall.

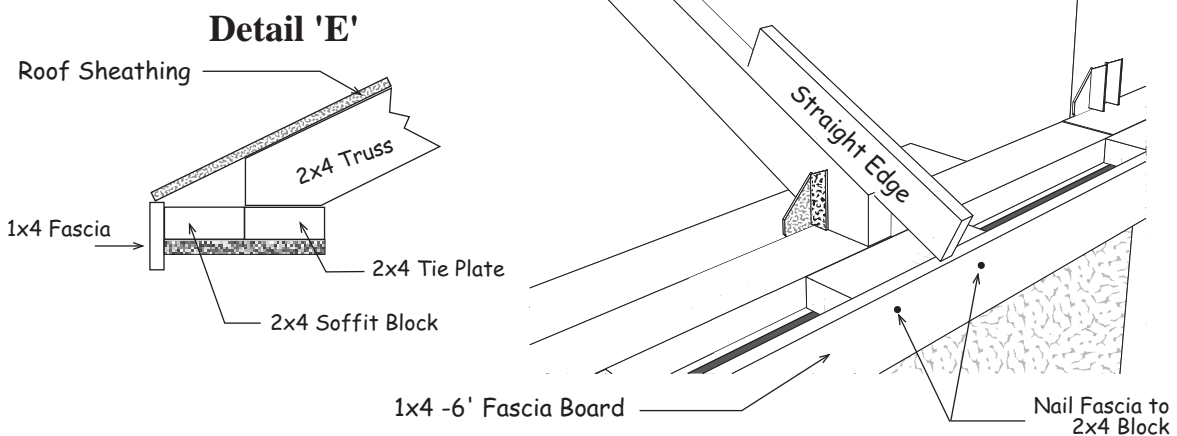

Step 25 Install Roof Sheathing

1. Locate (2) two 48"x85-3/4" OSB sheets. Cut both sheets to the these measurements.



These sheets were used to package the material in the extension kit.

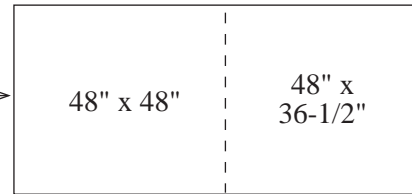

2. Install roof sheathing per layout below. Starting at rear of building install a 48"x72" OSB roof panel flush with rear gable trim. Plumb each truss and make sure the sheets meet at center of truss. Use 6d common nails spaced 12" apart. The top row of roof sheathing will be about 1" below the ridge to allow for optional ventilation. **Important:** Make sure the front gable is plumb and the roof sheathing extends 7-1/2" past the siding on the face of the gable.

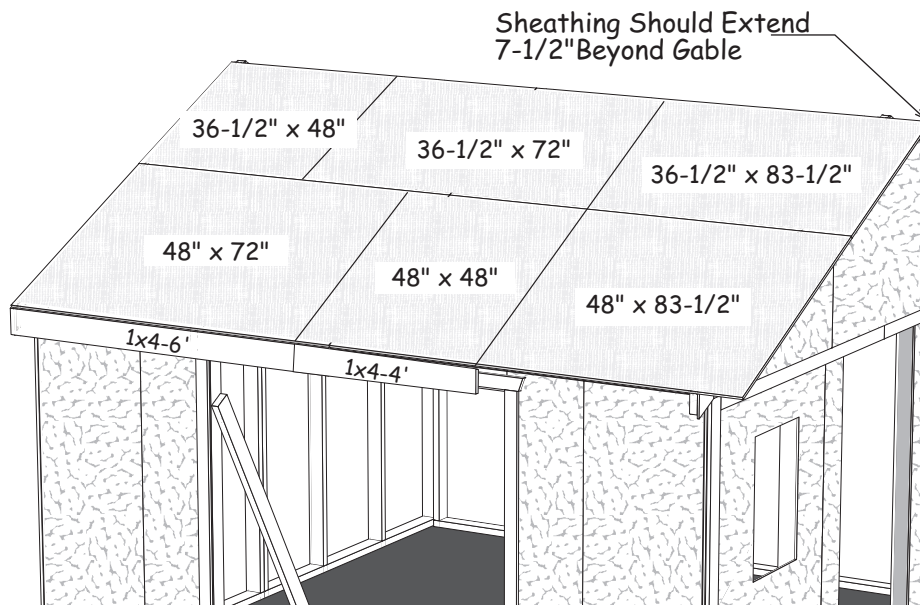

Step 26 Install Single Door Trim

1. Locate (2) two 1x3-72" long trim boards. Tack these, *with a couple nails*, flush to each side of the door opening and against bottom of upper trim. The trim may need to be moved when installing the door. Use 6d galv. nails.

1x3 Door Trim

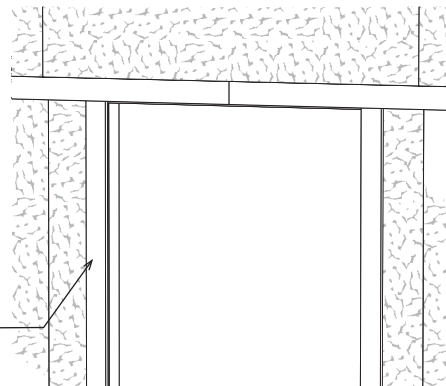

Step 27 Install Front Gable Soffit and Finish Fascia

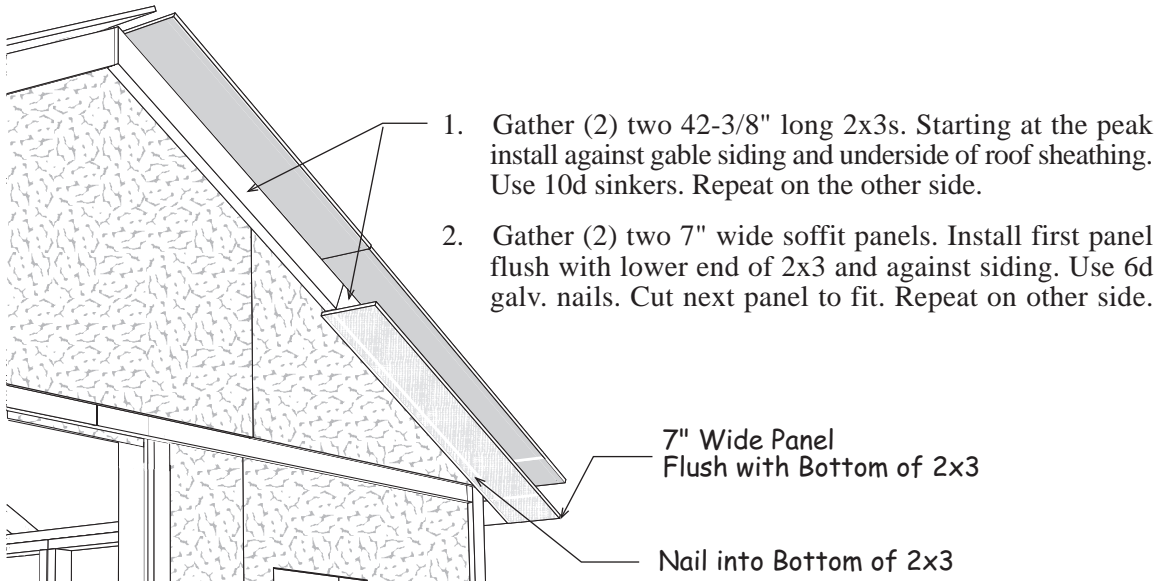

3. Starting at the peak install (2) two 42-3/8" long 2x3s between the roof sheathing and the 7" soffit panels. Use 6d galv. nails on soffit and 6d common nails through roof sheathing. Set these boards flush with soffit panels. Roof sheathing will extend past 2x3 boards. Repeat on other side.
4. Install gable trim and keystone over the 2x3 boards and under the roof sheathing. Use 6d galv. nails.
5. Return to side walls and cut the last 1x4-7' fascia boards to fit.

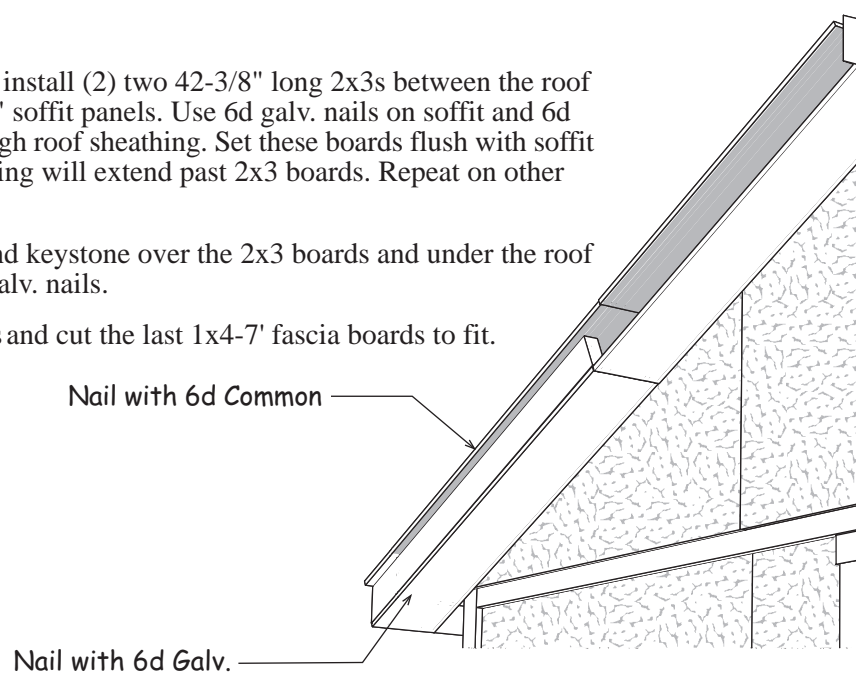

Step 28 Install Hardware

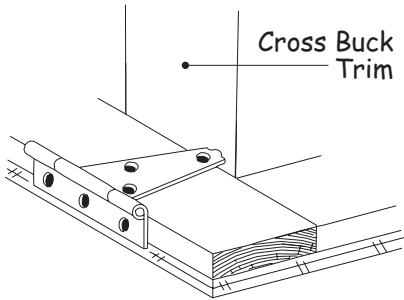

Install Hinges on Double Barn Doors

1. Locate the door that has a 2x4 fastened, *on edge*, to the back side of the door. See **Step 24**. This is the right door. Lay the door with the trim facing up and install 5" hinges to the left side of the door trim. To position the hinge properly, hold the rectangular plate against the frame. Use 1-3/4" black screws..
2. Install hinges to the left side of the other door.

Step 29 Install Door Stiffener on Single Door

Locate the 28" wide door. This door will be installed in the front door opening. The instructions below describe installing a 2x4 as a door stiffener. Decide which way the door will open and secure the 2x4 on the opposite side where the hinges will be installed.

1. Locate a 68-1/2" long 2x4 and position the 28" door with trim facing up. Place the 2x4 on edge under the door. The 2x4 should be 1-1/2" from long edge of trim and 1-1/2" from bottom of trim. Use a 2x4 block as a gauge and another to help level door while installing 2x4.
2. Fasten the 2x4 to the door using (6) six 2-1/2" long deck screws. Install the first screw 6" from the bottom of the door. Space the remaining screws 12" apart.
3. Install hinges as described in **Step 28** on opposite side of 2x4.

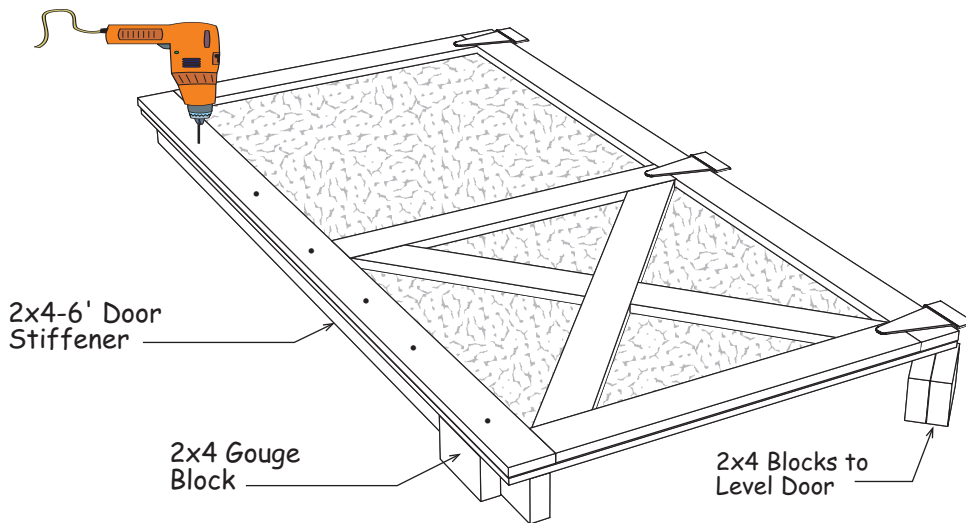

Install the door hinges on the opposite side of the door if you want the door to open in the opposite direction

Step 30 Install Doors & Hardware

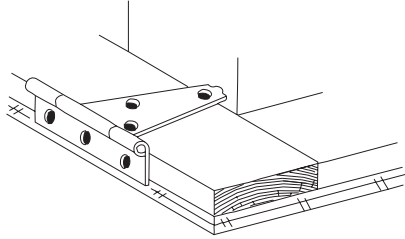

1. Lay the left door with the trim facing up. The siding on the left door extends past the door trim. See detail below.
2. Install 5" hinges to the left side of the door frame. To position the hinge properly, hold the rectangular plate against the frame. Use 1-1/4" black screws.
3. Install hinges to the right side of the other door.

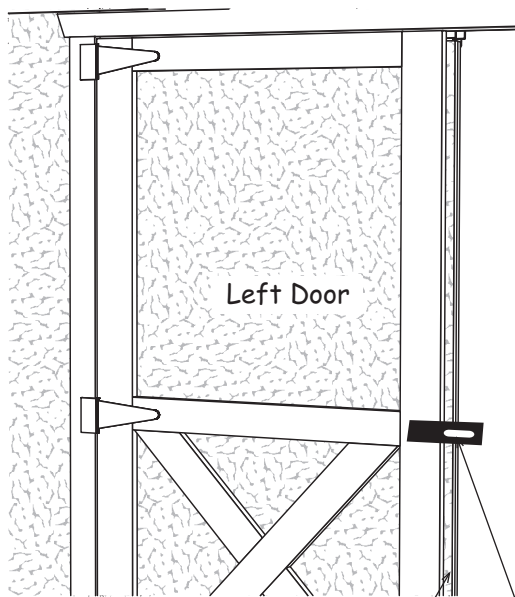

4. Before fastening the hinges to the side trim, temporarily prop the doors in the opening. Leave a space at the top and bottom of the doors and between the doors and the side trim to allow room for the doors to expand due to humidity.

If your door opening is out of square, the space around the doors will not be even. You can remove and re-position the side trim to make allowances for this. The side trim does not have to be flush with the frame of the door opening. You can move the trim in or out to make the door spacing equal.

5. Determine position of hinges and install to side trim with 2" screws.
6. Install door hasp on double doors. When properly installed the hasp will fold in half to receive locking latch and the screw heads will be covered.

Siding Extends Past Trim

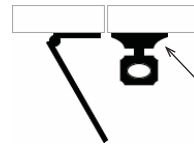

Fold Hasp to Cover Screws

Barrel Bolt on the back of left door

7. Install a barrel bolt on the lower back of the door to secure this door in place when closed. You will need to drill a hole for the round shaft to drop into.
8. Install another barrel bolt at the top of the door.

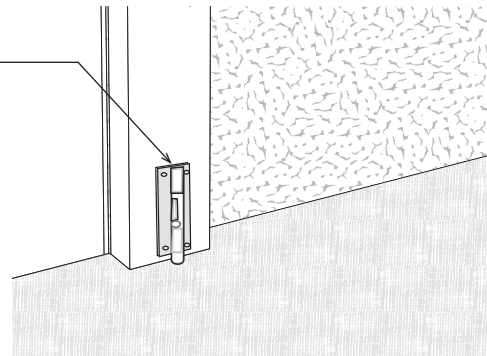

Step 31 Install Roofing — Not Supplied in Kit

1. Install metal roof edging on the perimeter of the roof area. If you are not installing shingles at this time, you can purchase felt paper to protect the roof sheathing. Install the felt paper before you install the metal roof edge.

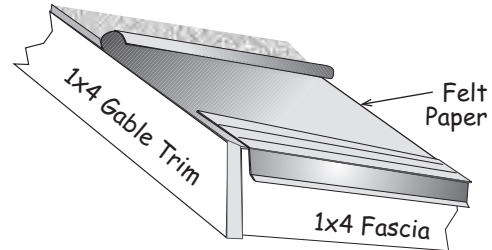

2. Install shingles according to the instructions on the wrapper. If you need more detailed instructions on installing shingles, there are good publications online.

Building Tip: Install ridge vent in lieu of shingles caps. Ridge vent provides ideal ventilation, preventing heat and moisture from damaging your building or its contents.

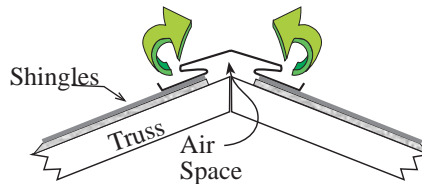

Optional ridge vent provides ideal ventilation.

Packing List for 4' Extension Kit

2	Collar Ties	2x4	82"	2	Siding Panels	3/8	48" x 75-3/4"
4	Rafters	2x4	80-1/2"	2	Soffit Panels	3/8	48" x 7"
6	Wall Studs	2x4	72"	2	Roof Sheathing	7/16"	48" x 85-3/4"
2	Wall Plates	2x4	48"	1	Lb.	10d Sinkers Nails	
4	Soffit Blocks	2x4	5" approx.	1	Lb.	6d Common Nails	
2	Fascia Trim	1x4	48"	4	ea.	H1 Truss Hangers	
4	Gussets	7/16	8" x 16"				

Packing List for Fairview Door Kit

1	Wall Stud	2x4	72"	3	ea.	5"	Door Hinges
1	Door Stiffener	2x4	68-1/2"	1	ea.	4.5"	Door Latch
2	Door Header	2x4	31-1/2"	14	ea.	1-1/4"	Hinge Screws
2	Door Trim	1x3	72"	14	ea.	2"	Hinge Screws
2	Siding Panels	9-3/4" x 75-3/4"		1	ea.	Pre-built Door 28" x 71-1/2"	
1	Siding Panel	48-3/4" x 4-1/4"		1	ea.	OSB Filler 3-1/4" x 31-1/2"	

Fairview Packaged In Component Kit

5	Collar Ties	2x4	82"	3	1 lb. box	10d	Sinkers
14	Truss Rafters	2x4	80-1/2"	2	1 lb. box		Hanger Nails
48	Wall Studs	2x4	72"	5	1 lb. box	6d	Galv.
4	Wall Plates	2x4	68-1/2"	3	1 lb. box	6d	Common
2	Wall Plates	2x4	67-1/2"	50	ea.	1-1/2"	Exterior Screws
2	Wall Plates	2x4	58-1/2"	80	ea.	2-1/2"	Deck Screws
2	Wall Plates	2x4	34-3/4"	6	ea.	5"	Door Hinges
4	Gable Studs	2x4	23-1/2"	1	ea.	4-1/2"	Door Latch
8	Boards	2x3	42-3/8"	2	ea.	6"	Barrel Bolts
10	Truss Gussets	7/16"	8" x 16"	25	ea.	2"	Hinge Screws
2	Fascia Boards	1x4	84"	25	ea.	1- 1/4"	Hinge Screws
2	Fascia Boards	1x4	72"	6	ea.	1x4	Metal Plates
10	Siding Panels	48" x 75-3/4"		10	ea.	2x4	Metal Truss Hangers
2	Siding Panels	16" x 75-3/4"		1	ea.		Bottle Glue
2	Siding Panels	48" x 4-1/4"		2	ea.		Plywood Gussets 3-1/2" x 32"
2	Gable Siding Panels	48" x 40"		1	ea.	OSB Filler	3-1/2" x 67-1/2"
4	Gable Siding Panels	48" x 28"		4	ea.	Front Soffit	7-1/2" x 48"
11	Siding Panels	3/8" x 7" x 48"		18	ea.	2x4 Truss Jig Blocks	6" to 8"
6	Filler Panels	3/8" x 4-1/4" x 48"		2	ea.	1x6 Keystone	8-1/2"
2	Roof Sheathing	48" x 72"		4	ea.	1x4 Gable Trim	81"
2	Roof Sheathing	48" x 84"		4	ea.	1x4 Corner Trim	75-3/4"
2	Roof Sheathing	36-1/2" x 72"		4	ea.	1x3 Corner Trim	75-3/4"
2	Roof Sheathing	36-1/2" x 83-1/2"		4	ea.	1x4 Wall Trim	72"
				3	ea.	1x3 Door Trim	72"
				2	ea.	Pre-built Door	32" x 71-1/2"

Roof Shingles by Owner

Qty.	Optional Shingles
10 bdl.	Roof Shingles
8 pcs.	Roof 'drip' Edge 10'