



Assembly Book
Revised April 30, 2024



the Belmont II

Building Size
12' x 20'

Manufactured by **RBS Holdings, LLC**
205 Arlington Drive Greenville, PA 16125

This manual is copyrighted. Under the copyright laws, this manual may not be copied, in whole or in part, without consent from RBS Holdings, LLC © Copyright 2022

IMPORTANT INFORMATION ABOUT YOUR KIT

Thank you for purchasing our kit. Please read the following information before beginning construction. Always check with your local HOA or building code office for any requirements or restrictions.

Floor: Wood flooring is sold optionally. You may choose to build your own or pour a cement pad.

Always wear safety glasses when cutting or nailing!

Tools Required:	Hand or Circular Saw	Level	Safety Glasses
	Cordless Drill	Measuring Tape	Dust Mask
	Hammer	6'-8' Ladder(s)	Screwdriver with Bits
	Pencil		Framing Square

Additional Materials - **Not included in kit:**

Windows are purchased separately

Required: Shingles or metal roofing, Drip Edge, Roofing Nails or Screws, Paint, Class 25 Sealant

Optional: Caulk, Ridge Vent

Terminology:

Square - Confirm corners are at 90 degrees

Plumb - Confirm walls and trusses are straight vertically

Wall Plate - Top and bottom 2x4s used to frame walls

Tie Plate - 2x4s connecting wall sections together

Header - Spans top of door opening

OSB - Oriented Strand Board

LAP - Edge of siding that overlaps

Tongue - Edge of siding that is overlapped

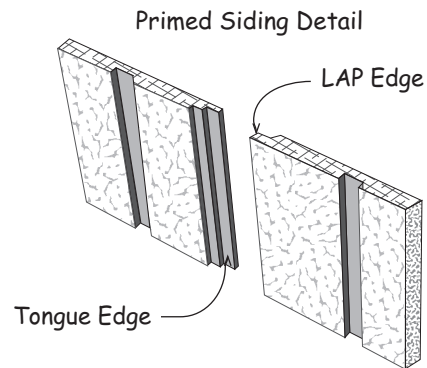

Organize:

Unpack all items & organize according to size and type. This will make items easier to find when instructed.

Review the parts list on the back page. Should there be missing items or sub-par material contact Best Barns Customer Service.

DO NOT discard any material including the pallet until your project is complete.

Assembly:

Review all instructions before you begin. Please follow steps carefully and in sequence for successful results.

If you have any questions we are happy to assist you. Please contact us at:

800-245-1577 - Mon - Fri 8AM - 5PM EST

724-866-4357 - After hours and weekends

Email - questions@barnkits.com

Details for Optional Deluxe Floor System

Foundation size is 12'-0" x 20'-0". Check local building codes in your area, the construction may have to change. For a concrete slab, install sill sealer as a moisture barrier between the concrete and the wall plates. Foam sill sealer can be purchased at home centers in rolls 3-1/2" or wider.

1. Stagger the 4x4 timbers as shown below. Cut (2) two 2x4- 8' boards into 2' long blocks to secure the 4x4s where they butt together.

2. Cut (2) two 2x4-8' to a length of 8' -0". They will be used for the joist headers. Layout, from left, for 16" on center joist spacing. 'X' marks where floor joist will be placed.

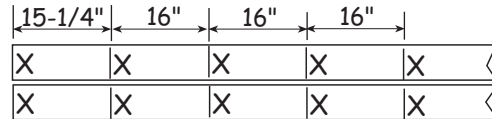

3. Cut (17) seventeen 2x4-12' treated boards to 11' -9". These will be the floor joists. *Treated lumber may be thicker than 1-1/2"*. Take this into account when cutting the length of floor joists. *Shorten joist measurements if necessary to obtain 12'-0" building width.*
4. Install the floor joists cut above between the 8' joist headers. Secure with 16d galv. deck nails.
5. Place floor assembly over the 4x4s. Square floor assembly. Measure the floor diagonally (corner to corner) and then the opposite corners; these measurements will be the same when the floor is square. Toenail frame (headers & joists) to the 4x4 runners.

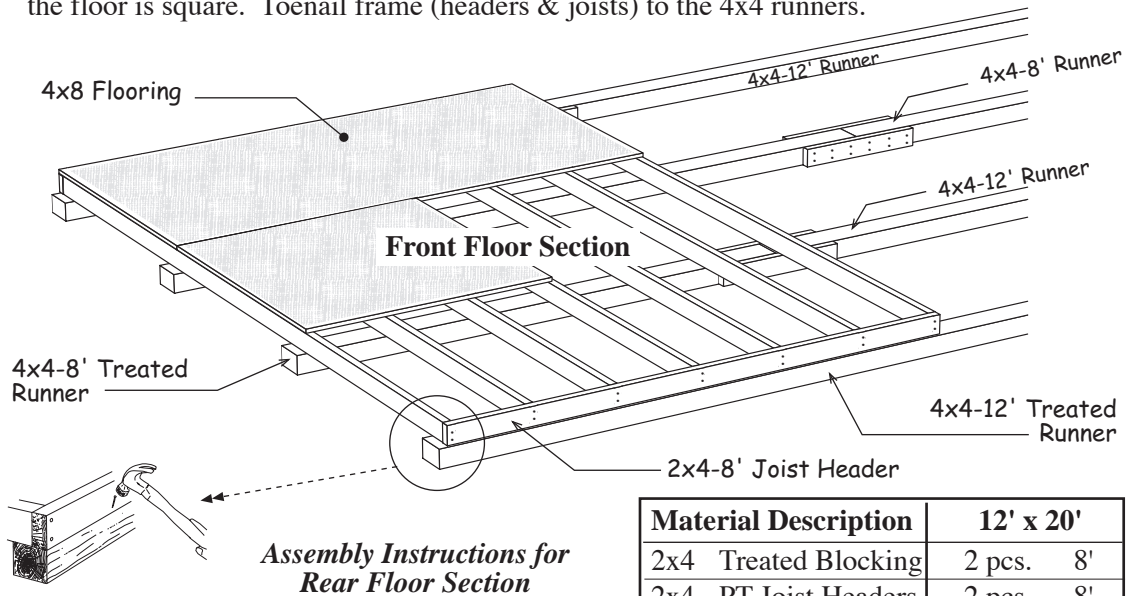

6. Cut (2) two 2x4-12' to a length of 12' -0". Layout for 16" joist spacing, *See above.*
7. Install floor joists between the joist headers. Square the floor section and install against the section assembled above. Toenail to the 4x4s runners.
8. Install 4x8 flooring over the 2x4s. Use 8d galv. spiral nails spaced 8" apart.

Material Description	12' x 20'
2x4 Treated Blocking	2 pcs. 8'
2x4 PT Joist Headers	2 pcs. 8'
2x4 PT Joist Headers	2 pcs. 12'
2x4 PT Floor Joist	17 pcs. 12'
4x4 Treated Runners	4 pcs. 8'
4x4 Treated Runners	4 pcs. 12'
Flooring 5/8" or 3/4"	8 pcs. 4x8
Galv Spiral Floor Nails	3 lb. 8d
Galvanized Deck Nails	5 lb. 16d

Step 1 Assemble 12' Back Wall

1. Cut (2) two 2x4-12' to a length of 144". Position the boards together and indicate with 'X' marks where the wall studs will be located.

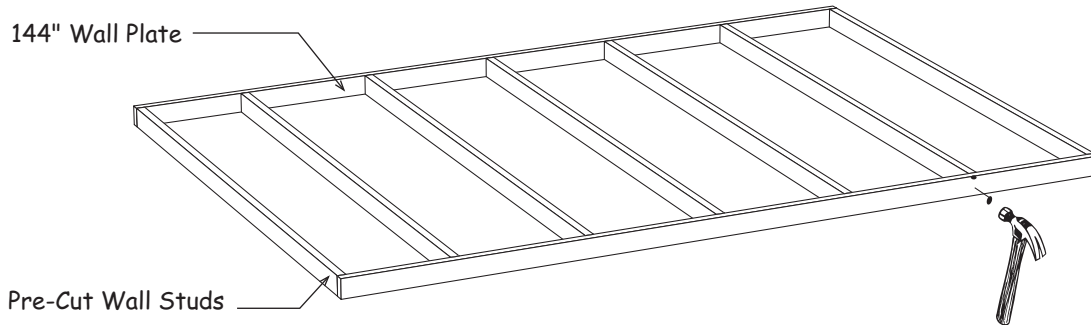
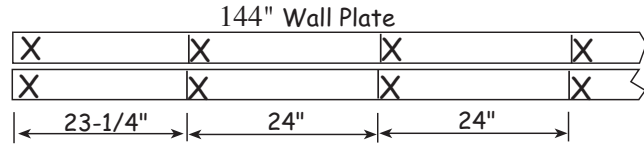

Depending on your location pre-cut wall studs vary in length from 92-1/4" to 93". This doesn't affect construction.

2. Install (7) seven pre-cut wall studs between the top & bottom plates. Nail studs to wall plates with 10d sinkers, (2) two nails on each end.
3. Square wall frame. Measure the wall diagonally (corner to corner). Then measure the opposite corners. These measurements will be the same if the wall is square.

4. Install the first siding panel with the 'LAP' edge flush with the end of the wall. Siding will extend 3/4" below the bottom plate. Nail siding with 6d galv. nails, spaced 8" apart.

Tip: use a 1x4 trim board as a gauge.

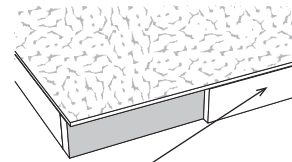

5. Install (2) two more siding panels. If necessary cut the last panel flush with the end of the frame.

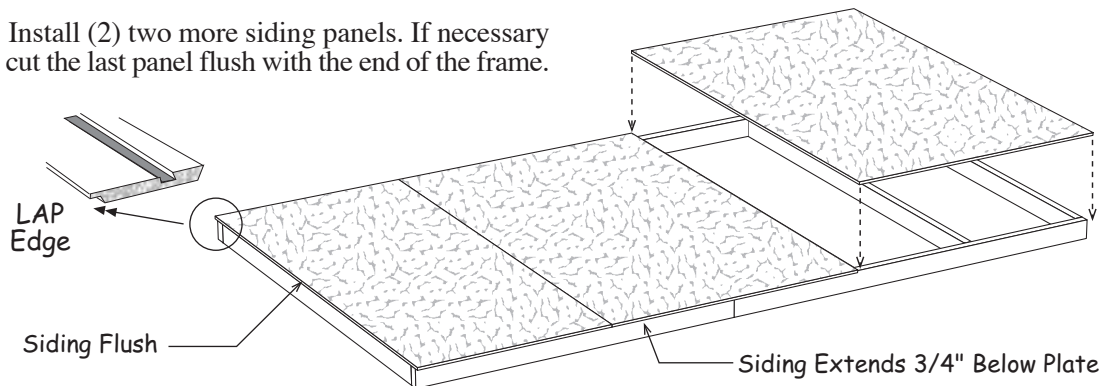

Step 2 Assemble 10' Side Wall Frames

1. Cut (2) two 2x4-10' boards to a length of 116-1/2". Position the boards together and indicate with 'X' marks where the wall studs will be located.
2. Mark a 'C' anywhere between first two stud marks. This is referenced in a later step.

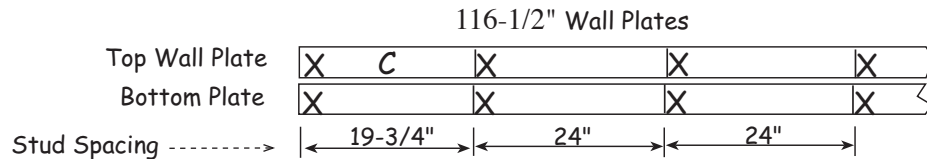

3. Install (6) six pre-cut wall studs between the top & bottom plates with (2) two 10d sinkers on each end.

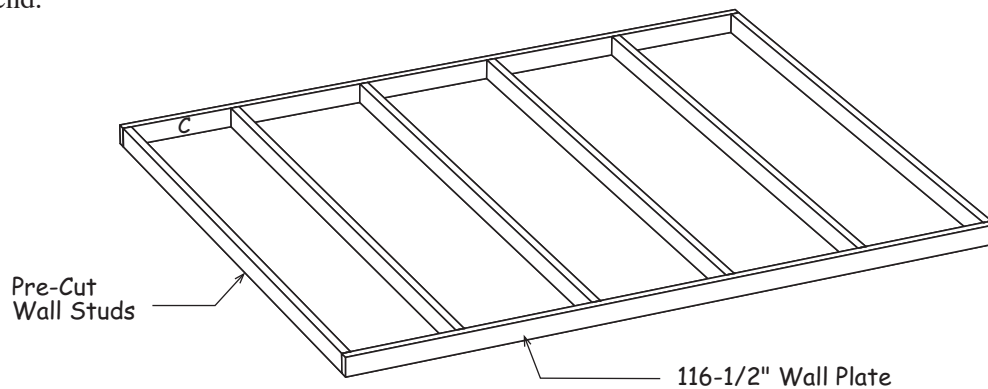

4. Repeat to assemble (3) three more 116-1/2" long wall frames. The siding will be applied after the walls are set on the floor.

Step 3 Assemble Door Header

1. Locate (2) two 2x8-8' boards. Cut these boards to a length of 75".
2. Assemble the door header using 2x8 boards and (2) two 7-1/4" x 48" OSB filler included in our kit. Install (1) one 48" long filler flush with end of 2x8. Cut to fit second OSB filler. Nail together with (12) twelve 10d sinkers spaced evenly on each side.

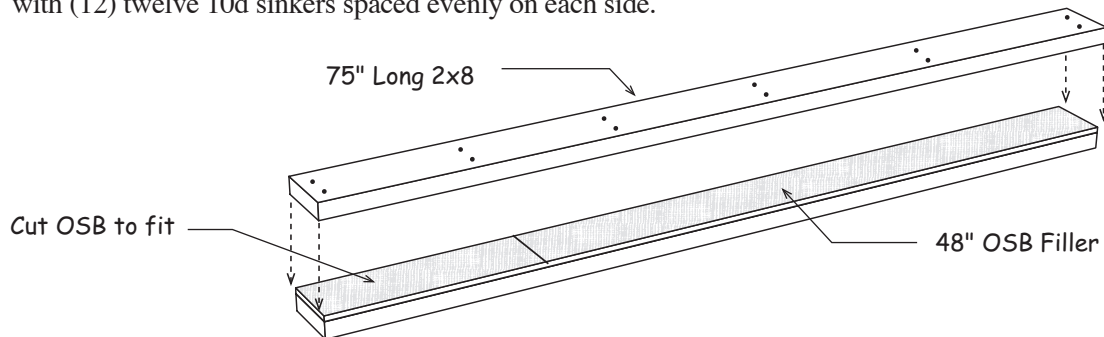

Step 4 Assemble Front Wall Frame

1. Cut (2) two 2x4-12' boards to a length of 144" for wall plates. Position the boards together and indicate with 'X' Marks where the wall studs will be located.

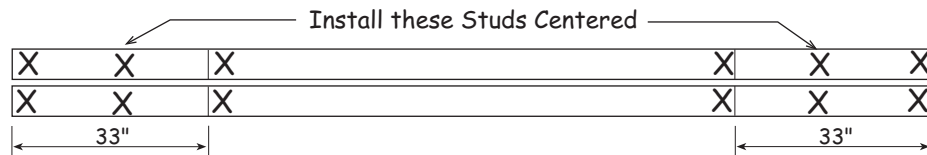

2. Install (6) six pre-cut wall studs between the wall plates where shown.

3. Cut (2) pre-cut studs to a length of 78-1/2" and install as header supports where shown. Nail to studs with 10d sinkers.

4. Install the door header on the 2x4 header supports. Nail to the stud with 10d sinkers.

5. Measure space between header and top plate. Cut from a pre-cut stud (4) four pieces to this length. Evenly space pieces and nail through top plate and toenail to header. Use 10d sinkers.

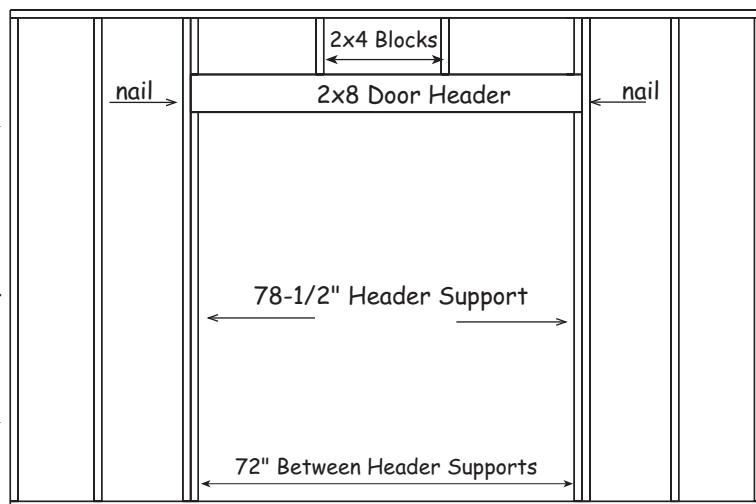

6. Place a full width siding panel with the 'LAP' edge flush with left side of wall frame. Siding should extend 3/4" below bottom plate. Before nailing siding, cut the siding flush with the side of the door opening and bottom of the door header.

7. Install a 20"x48" siding panel above the door opening. Cut the siding flush with the side of the door opening and bottom of the door header.

8. Install a full width siding panel on the right side of the wall panel. Cut siding as previously instructed.

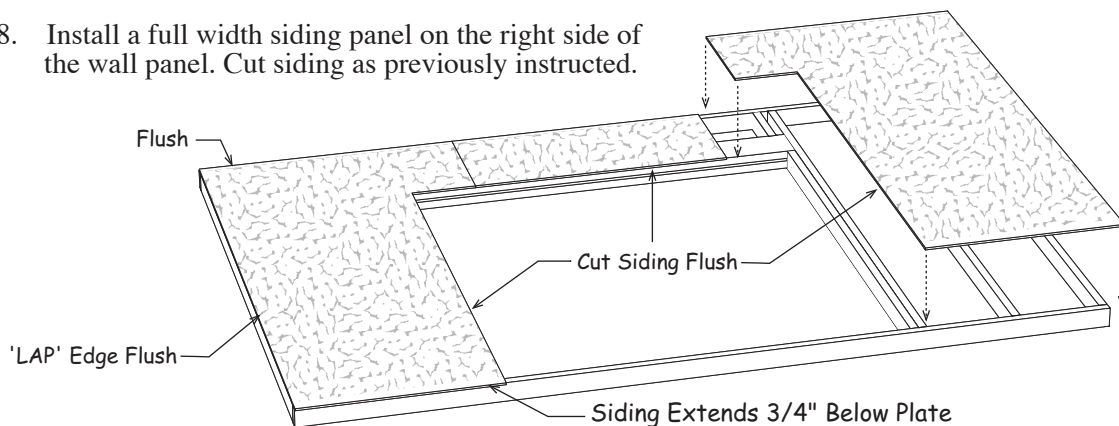

Step 5 Set Walls

1. Erect back wall and 10' side wall frames. **IMPORTANT:** Install the side wall frames with the 'C' marks oriented against the back wall panel and front wall corners. Secure walls together at the corners. Use (4) four 10d sinkers per corner. Brace walls with pre-cut wall studs to hold walls secure and plumb.
2. Starting at back corner install a full width siding panel with the 'LAP' edge flush with the siding on back wall. Siding should extend $3/4$ " below bottom plate. Nail siding to back wall and all 2x4s using 6d galv. nails spaced 8" apart.

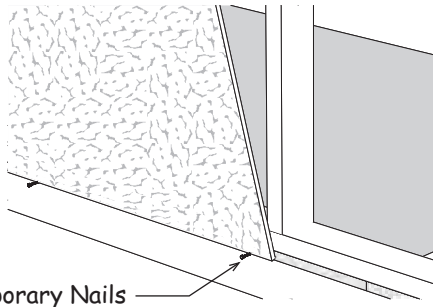

Tip: If you are erecting building on a wood floor insert nails between the $3/4$ " floor sheathing and the 2x4 floor frame. Rest the siding on the nails while nailing to frame.

3. Install (4) four more siding panels. Last panel will extend approximately $3-1/2$ " past wall frame to receive front wall panel.
4. Start at back wall apply siding to opposite wall.
5. Erect front wall panel and secure corners with 10d sinkers and nail side wall siding to 2x4s. Brace with pre-cut wall studs.
6. Cut and remove bottom 2x4 from door opening.
7. Nail walls to floor through bottom plate. Space 10d sinkers 24" apart.

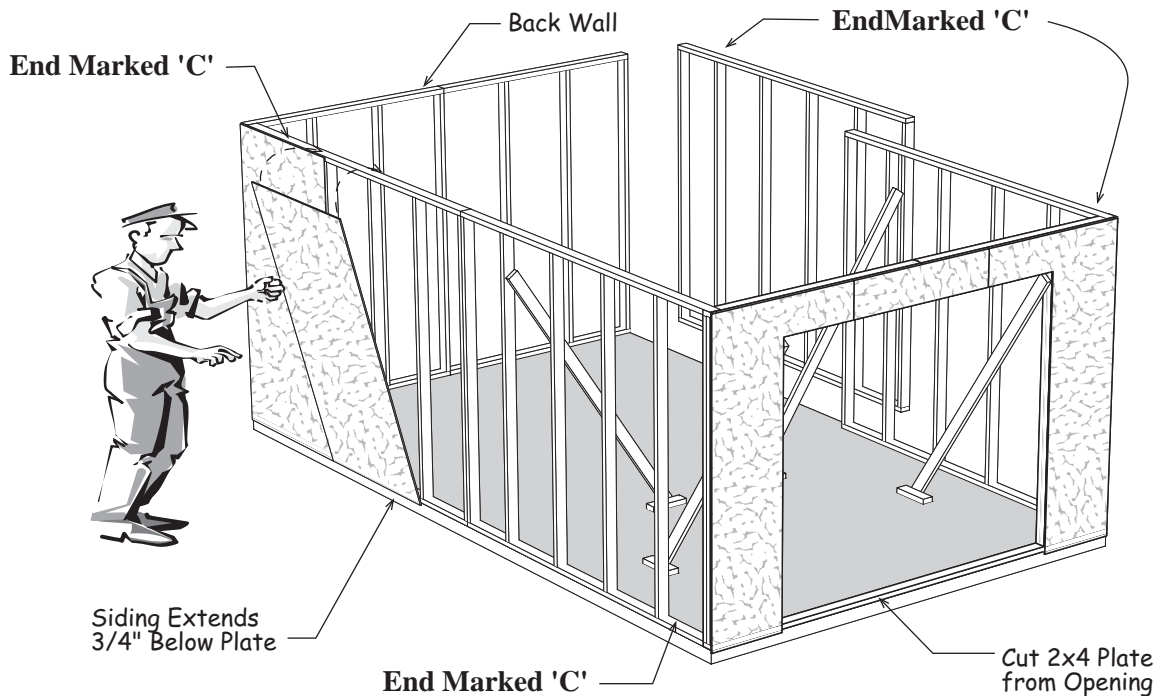

Step 6 Install 2x4 Tie Plates

1. Install a 2x4-8' on a side wall, flush with the 2x4 on the back wall. Install a 2x4-12' flush with the 2x4 on the front wall. Cut length to fit. Use 10d sinkers to secure the tie plates to front and back walls and along length.
2. Repeat to install 2x4s on the opposite side wall.
3. Cut (2) two 12' long 2x4s to fit between side wall tie plates and install on front and back walls.

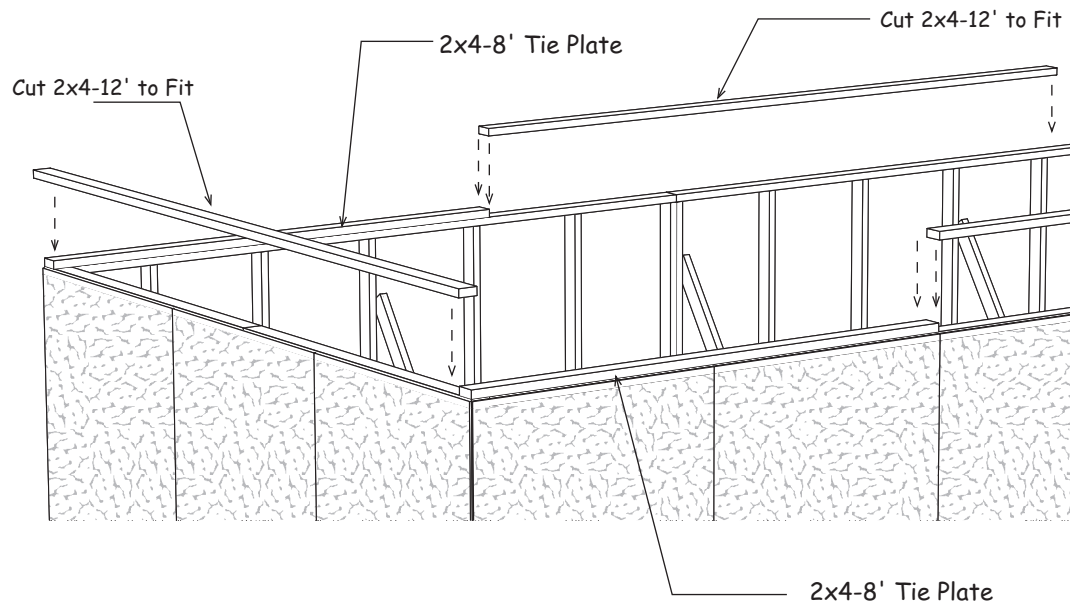

Step 7 Install Metal 2x4 Joist Hangers

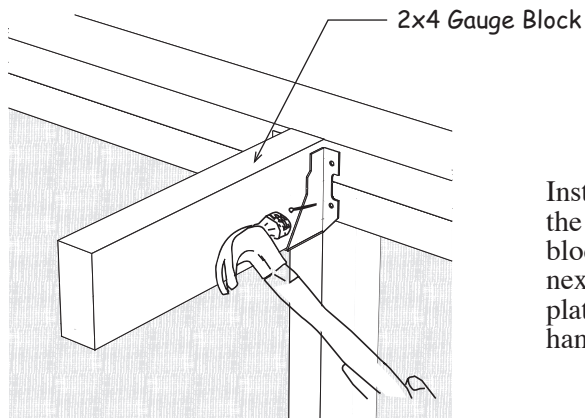

Install (18) eighteen 2x4 joist hangers aligned with the wall studs on both side walls. Use a short 2x4 block as a gauge to ensure the 2x4s, installed in next step, will be flush with the top of the 2x4 tie plate when installed. Secure the hanger with 1-1/2" hanger nails.

Step 8 Install Loft Floor

Important: Before securing the 2x4 floor joists make sure the side walls are plumb. The building width should be 12'-0" measuring from the outside of the 2x4 tie plates.

Cut (9) nine 2x4-12' boards to a length of 137" and install in the metal hangers. Use 1-1/2" hanger nails.

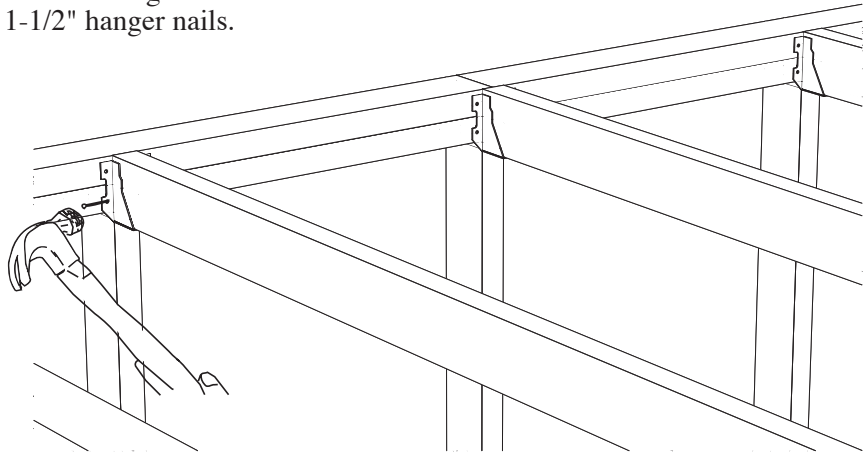

Step 9 Install Loft Floor Sheathing



Before installing floor sheathing consider where to locate the 2' x 4' access opening. The detail below shows one possibility. Regardless of desired layout it is important to install sheathing staggered when possible.

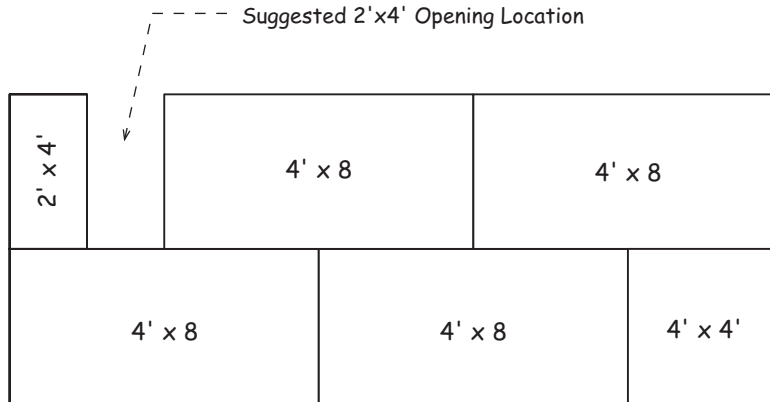

1. Locate (4) four 3-1/2" x 24" OSB fillers. Install at front and back corners on top of 2x4 tie plates. Use (4) four 6d common nails each. Insure the space between fillers is 96".
2. Install loft flooring between OSB fillers. Edge of sheathing should be flush with front and back wall tie plates. Refer to the suggested layout on previous page. Install flooring using 6d common nails spaced 12" apart.

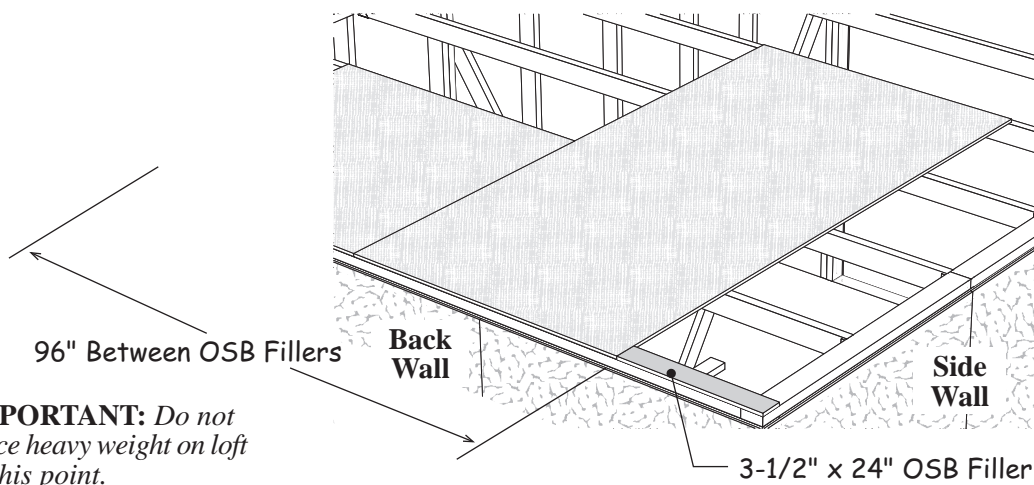

IMPORTANT: Do not place heavy weight on loft at this point.

Step 10 Install Corner Trim

IMPORTANT: Trim Must Be Installed Before Installing Roof Gables!

1. Locate (3) three 2" x 48-3/4" Siding filler strips. Nail these on top of the siding on the back wall. Use a few 6d galv. nails. More nails will be used on trim.
2. Locate (4) four 27" long and (4) four 72" long 1x3 trim boards. Install 72" long boards on the back wall at corners flush with side wall siding and top of OSB filler. Nail with (2) two 6d galv. nails 3/8" from top and bottom of board. Then nail staggered along board 12" apart. *See diagram below.*
3. Install 27" long boards under 72" long boards. Leave a gap of 3/16" to allow for sealant to fill gap. If necessary cut trim to be flush with bottom of siding. Fill gap with sealant.

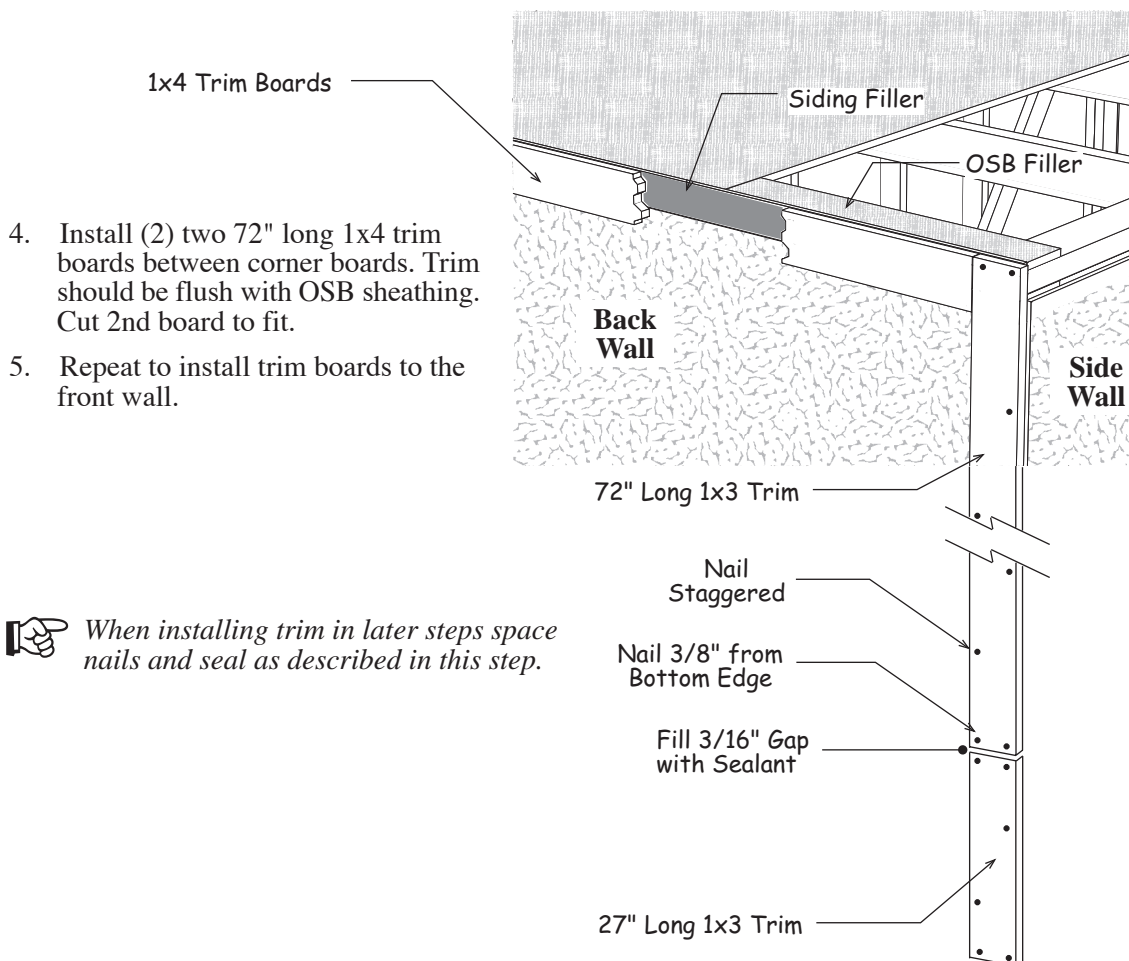

Step 11A Assemble Gables

1. Gather pre-built gable end frames, (1) one left and (1) right, (1) one 49-1/2" long 2x4 and (2) two 32-1/2" long 2x4s with angled ends.
2. Position these components together as shown below. When aligned correctly the bottom 2x4s will be straight and measure 12'-0" from end to end. *Pre-built gable ends highlighted in gray.*
3. Temporarily tack 1x4 blocks to loft flooring around the frame members. These blocks will be 8"-12" long and may have angled ends. Make sure (2) two of these blocks are positioned inside each pre-built gable end frame as shown. Position the rest of the blocks appropriately spaced to hold 2x4s in place. These will insure that all trusses and gables are built exactly the same. **DO NOT** nail blocks to gable.
4. Secure the bottom 2x4 to the gable stud using (2) two 2-1/2" screws.
5. Locate (2) two 5-3/4"x14" OSB gussets. Attach these to top of each gable stud to secure frame to 32-1/2" 2x4s. Use 6d common nails. See Detail 'A'.

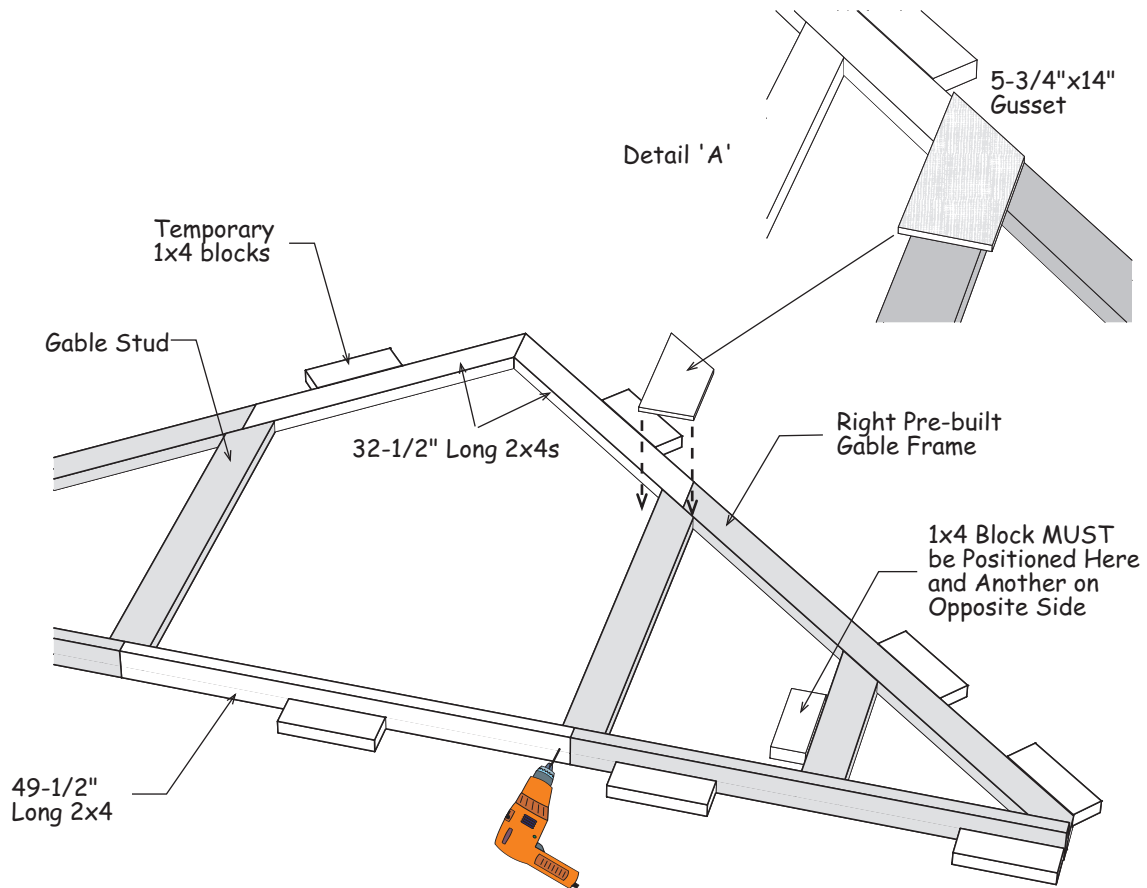

Step 11B Assemble Gables Continued

5. Locate (2) two 50-3/4" long 2x4s. Install these equally spaced from center of the gable. Secure the bottom 2x4 to the gable studs using (2) two 2-1/2" screws each.
6. Install a wood gusset at peak. Nail using (14) fourteen 6d common nails.
7. Locate (2) two 5-1/2"x27-3/4" gussets. Attach these to top of each gable stud to secure to the 32-1/2" 2x4s. Use 6d common nails.

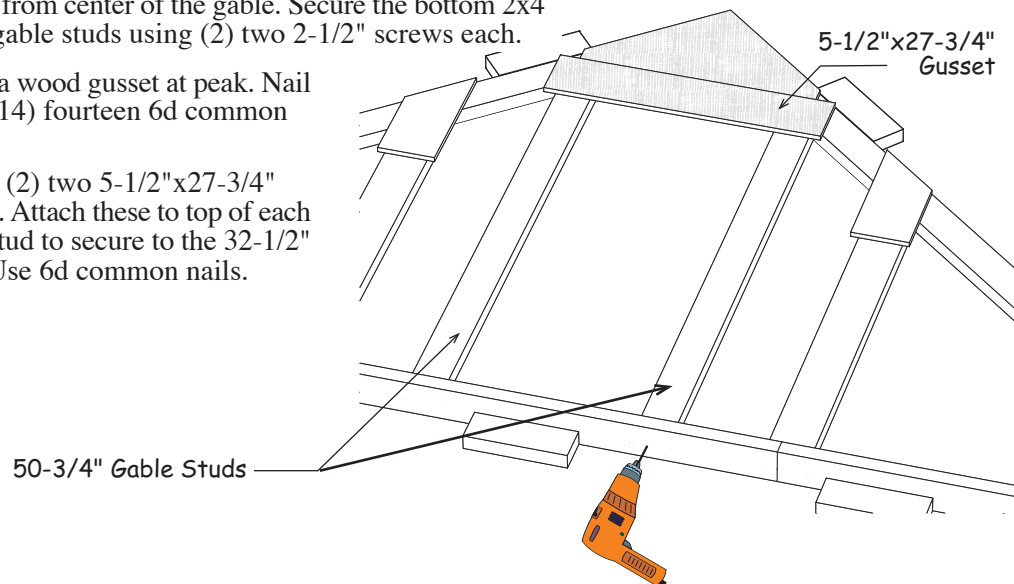

Step 12A Install Front Gable Siding

 *Gable siding is factory cut to be installed either working from left to right or right to left. Regardless of the direction always begin with the 'LAP' Edge flush with end of the gable.*

1. Carefully turn the gable frame over. Temporarily place 2x4s under the gable frame to keep the frame level while installing the gable siding.
2. Locate pre-cut gable siding. Install siding with 'LAP' edge flush with end of gable. Install with siding extending 3/4" below the bottom 2x4 plate. Use 6d galv. nails spaced 8" apart.

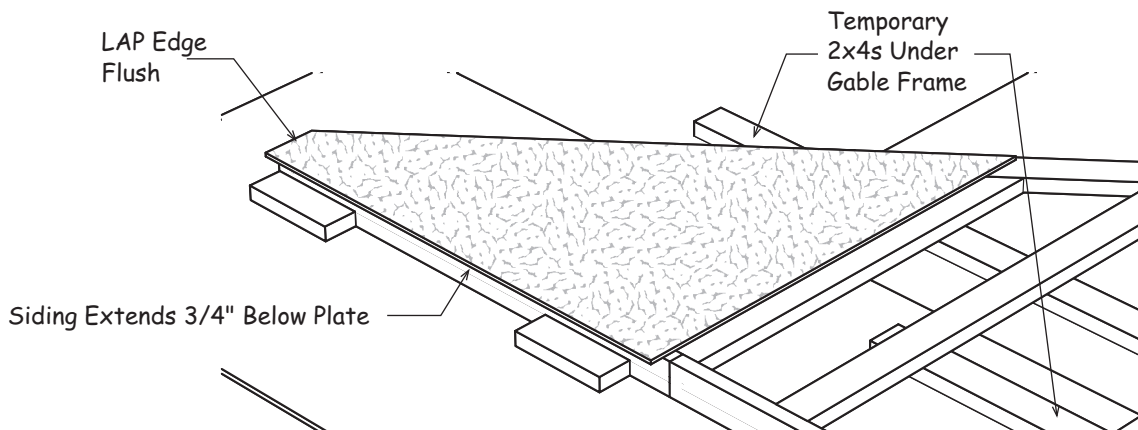

Step 12B Install Gable Siding continued

3. Install center siding. If you purchased a sunburst window you may cut the opening in the siding at this time. Instructions are packed in the window box. It is advisable to install the window after the gable is set

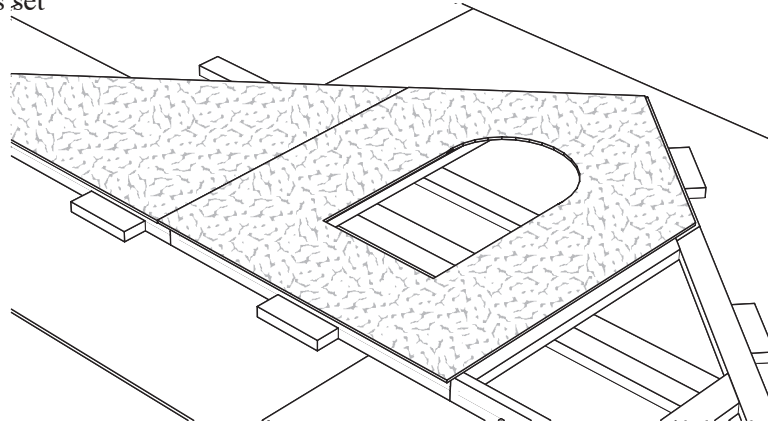

4. Install last siding panel.

Step 13 Install Gable Overhang

1. Locate (2) two 77-3/8" long 2x4 rafters on gable. Install 2x4s flush with the top of gable frame. Use 10d sinkers.
2. Locate (2) two 30-3/4" long 2x4 rafters and install to finish. 2x4s will extend beyond end of gable.

Do not remove the temporary 1x4 blocks until the roof trusses and back gable are assembled.

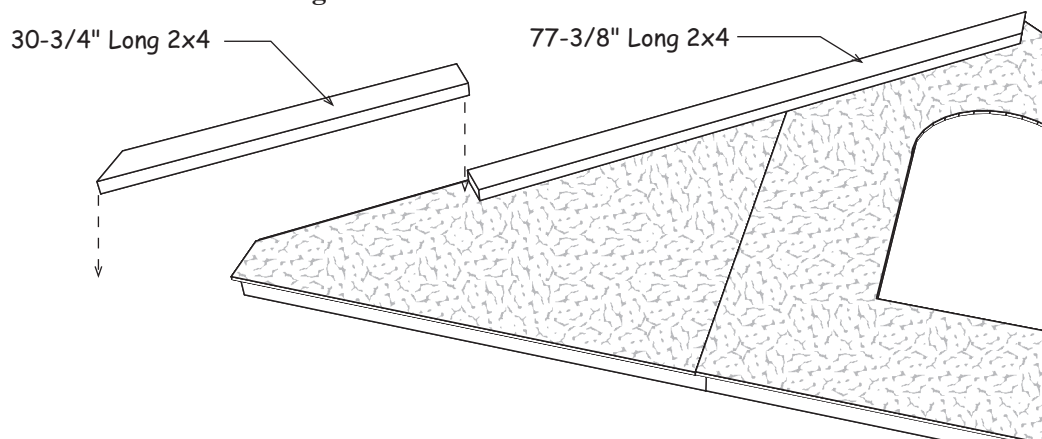

Step 14 Set Front Gable

 **Important: Temporarily brace the gables with 2x4s to secure gables until the roof sheathing is installed!**

1. Install gable on the front wall. Secure bottom of gable to loft floor and OSB fillers using 10d sinkers.
2. Nail the bottom edge of the siding into the 1x4 trim. Use 6d galv. nails.

Bottom edge of gable siding extends over 1x4 trim

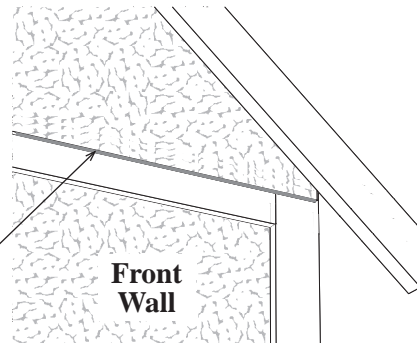

Step 15 Assemble Rear Gable

Repeat Steps 11 through 13 to assemble and set rear gable.

Step 16 Assemble Roof Trusses

1. Insert left and right pre-built truss ends into the blocks that held the gable frames in place. Insure span is 12'-0" between truss ends as indicated in drawing below.
2. Butt (2) two 77-3/8" long 2x4s against the truss ends. Remove the 1x4 blocks that secured the bottom gable plate and reposition to keep rafters aligned. Locate a 18-1/2" long 2x4 ridge block with angled ends and install at peak. Secure rafters and ridge block at peak with a wood gusset. Install with (14) fourteen 6d common nails.
3. Install gussets on truss ends. See Detail A. Install with (20) twenty 6d common nails.
4. Carefully flip truss over and install another gusset at the peak.
5. Set truss aside. Repeat steps to build (8) eight more trusses.
6. Remove temporary 1x4 blocks.

 **Tip: Place a gusset under rafters to help level.**

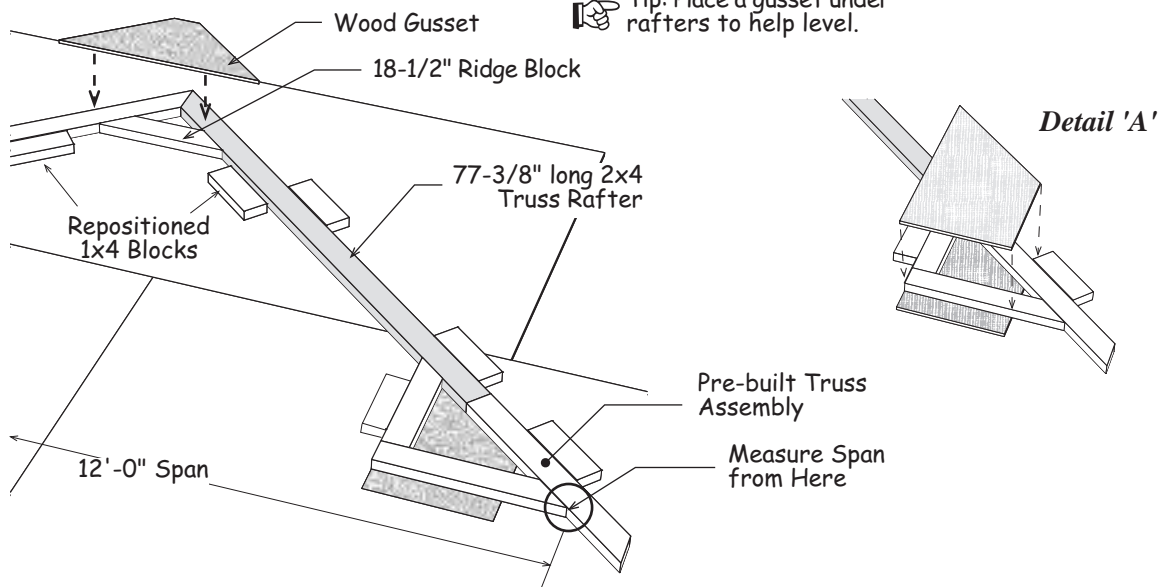

Step 17 Set Trusses

1. Starting at back gable set a truss by sliding ends over 2x4 floor joist. Truss ends should set flat atop floor joist. Secure with (10) ten 6d common nails on both sides.
2. Continue standing trusses to front of building. Make sure trusses and gables are plumb. If necessary span a 2x4 across tops and tack to keep plumb until roof sheathing is installed.

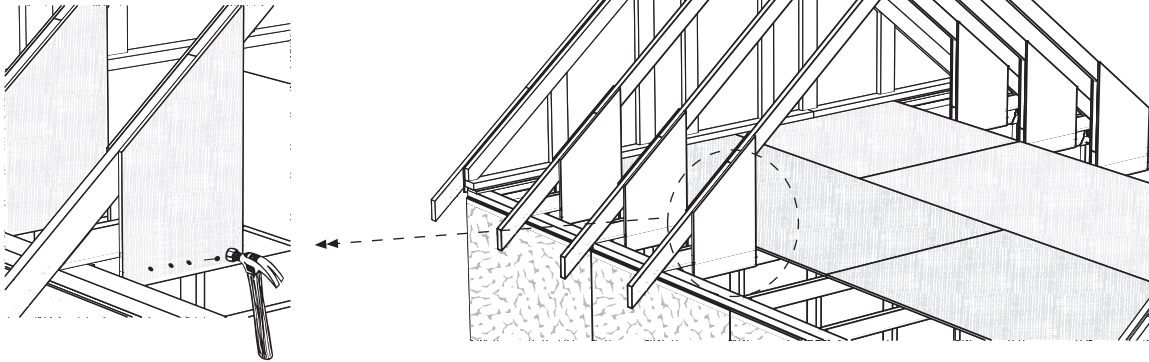

Step 18 Install Side Wall Trim

 *It's easier to install the soffit if the corner and side wall trim are installed first. This enables the soffit to rest on the trim where it meets the building. See lower detail.*

1. Locate a 3/8" x 3" x 8" siding gauge block packed in the hardware bag. Place this gauge block under the 2x4 overhang and butt a 72" long 1x4 trim board against it. Install trim flush with the corner trim on the back of the building. Use 6d galv. nails.
2. Install a 27" long 1x4 under 72" board.
3. Repeat to install corner trim at the other three corners.
4. Install (3) three 72" long 1x3 trim board along the top of the side wall. Use the gauge block to properly set trim. Cut a 4' long 1x3 board to finish.
5. Repeat on opposite side wall.

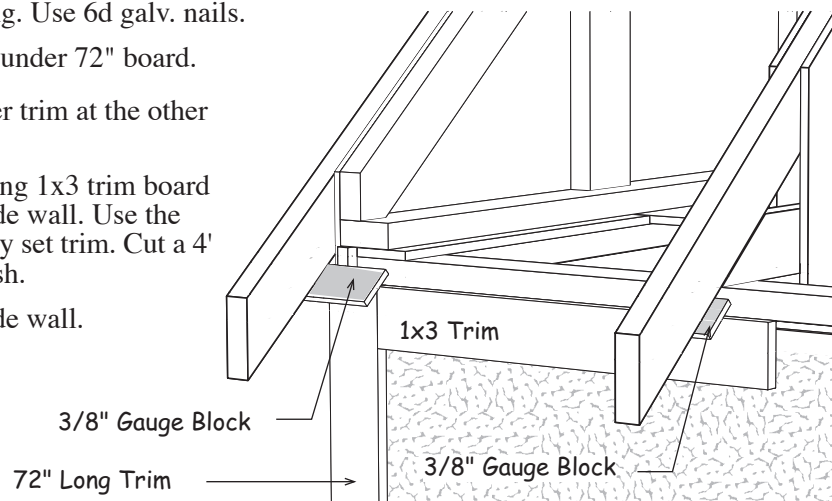

Step 19 Install Soffit

1. Locate (4) four 9-3/4" x 48" soffit panels. On the front gable nail first soffit with the 'LAP' edge positioned 9-3/4" from the bottom end of the 2x4 to allow for the width of the soffit panels on the side walls. Use 6d galv. nails.
2. Cut to fit next soffit to cover 2x4 at the peak. Install (2) two soffit panels on other side.
3. Locate (6) six 9-3/4" x 48" soffit panels. Measure from center of first truss to edge of soffit on gable. Cut a soffit panel to this length. Make sure 'LAP' edge is the side cut off.
4. Nail the soffit panel to the end of the 2x4s. See **Detail 'C'** below.
5. Install more soffit panels along the side of the building cutting the last soffit panel flush with the 2x4 on the rear gable.
6. Repeat steps 3-5 to install soffit panels on the front gable and the opposite side wall.

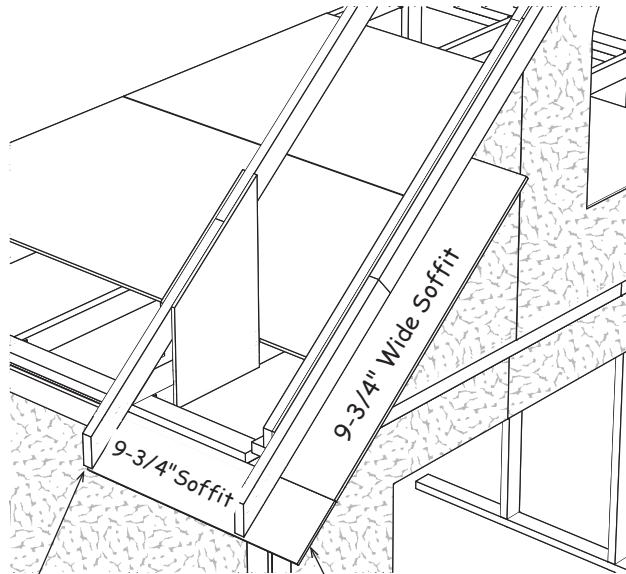

Tongue Edge at
Center of Truss

Cut Edge

Detail 'C'

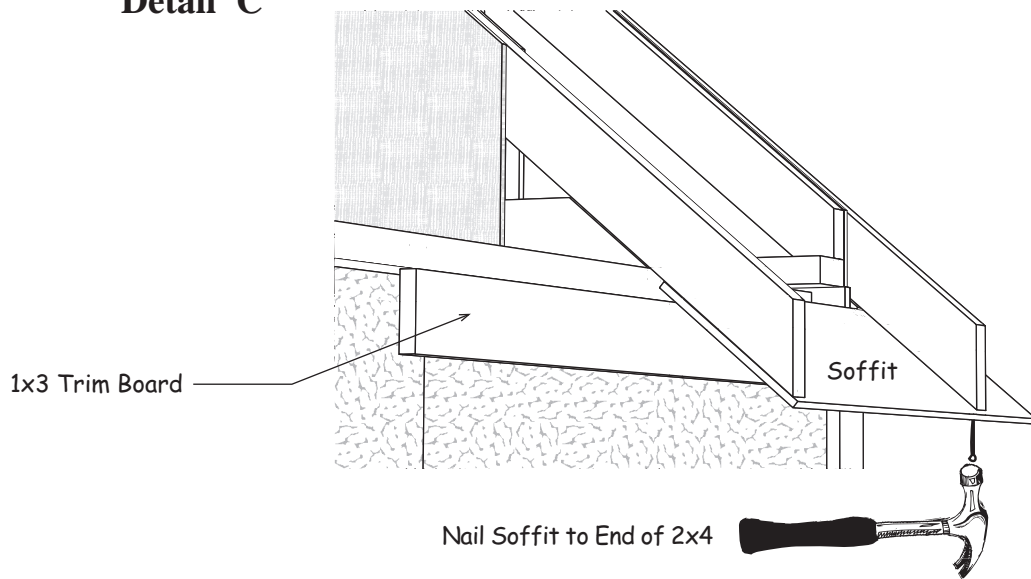

Step 20 Install 1x6 Fascia on Side Walls

1. Starting at the back gable, install a 75" long 1x6 trim board flush with the face of the 2x4. Install the 1x6 board so the top of the board is aligned with the top of the trusses. The roof sheathing, *installed later*, should rest on the fascia. Use a straight edge as shown below. Use 6d galv. nails.
2. Install (2) two 1x6-6' trim boards next. Cut a 48" long 1x6 trim board flush with the front soffit overhang to finish.
3. Repeat on opposite side wall.

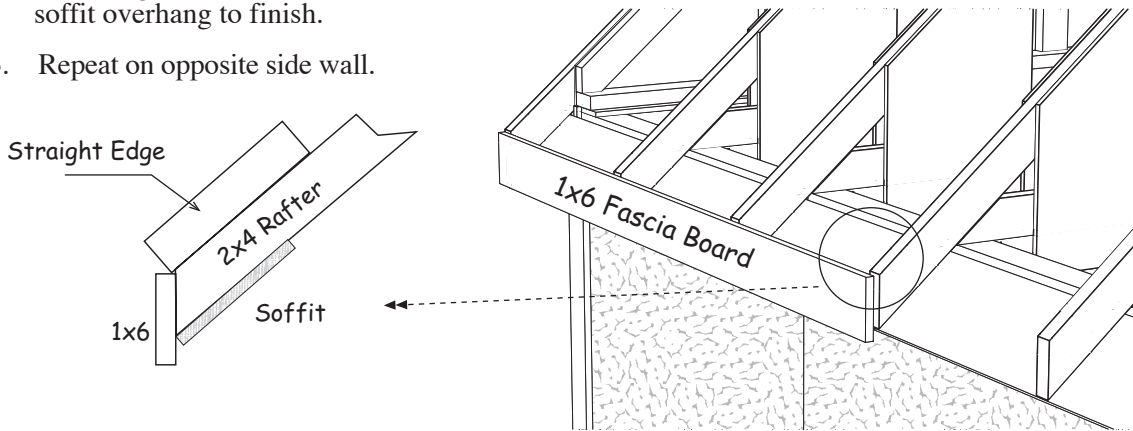

Step 21A Install Roof Sheathing

1. Locate (2) 48"x96" sheets of OSB. Cut from these (2) two 48"x59-1/4" sheets. From drops cut (2) two 48"x35-1/4" sheets.
2. Locate (2) 48"x96" sheets of OSB. Cut these in half to make (4) four 48"x48" sheets.
3. Following layout below install roof sheathing according to instructions on next page.

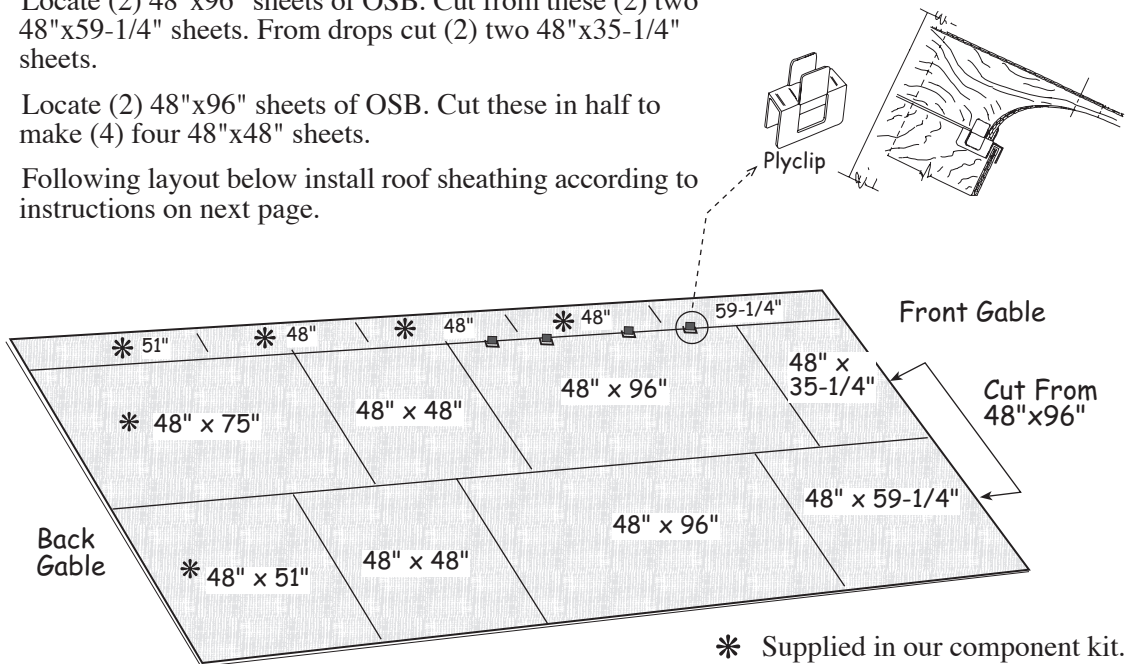

Step 21B Install Roof Sheathing continued

1. Make sure the trusses and gables are plumb.
2. Refer to the roof sheathing layout. Install a 48"x59-1/4" sheet at lower front corner. Sheathing should be flush with soffit and rest on 1x6 fascia. Secure sheathing with 6d common nails. Space nails 12" apart. Continue installing to back gable.
3. The top row of sheathing will allow a gap at the top for ventilation if ridge vent is applied. Insert (2) two ply-clips into the roof sheathing between each truss at the top row, see drawing on previous page.

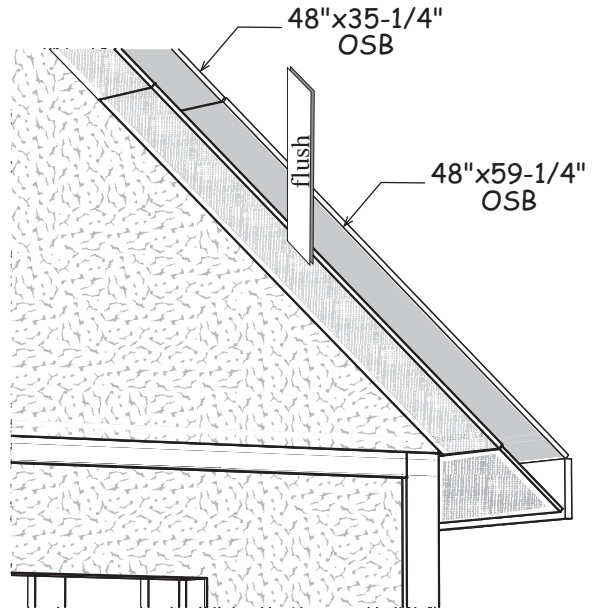
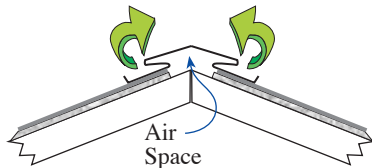

Step 22 Install 2x4s in Front overhang

1. Starting at the peak install a 77-3/8" long 2x4 between the roof sheathing and the soffit panels. Set this board flush with edge of soffit panels and roof sheathing. Use 6d galv. nails on soffit and 6d common through the roof sheathing.

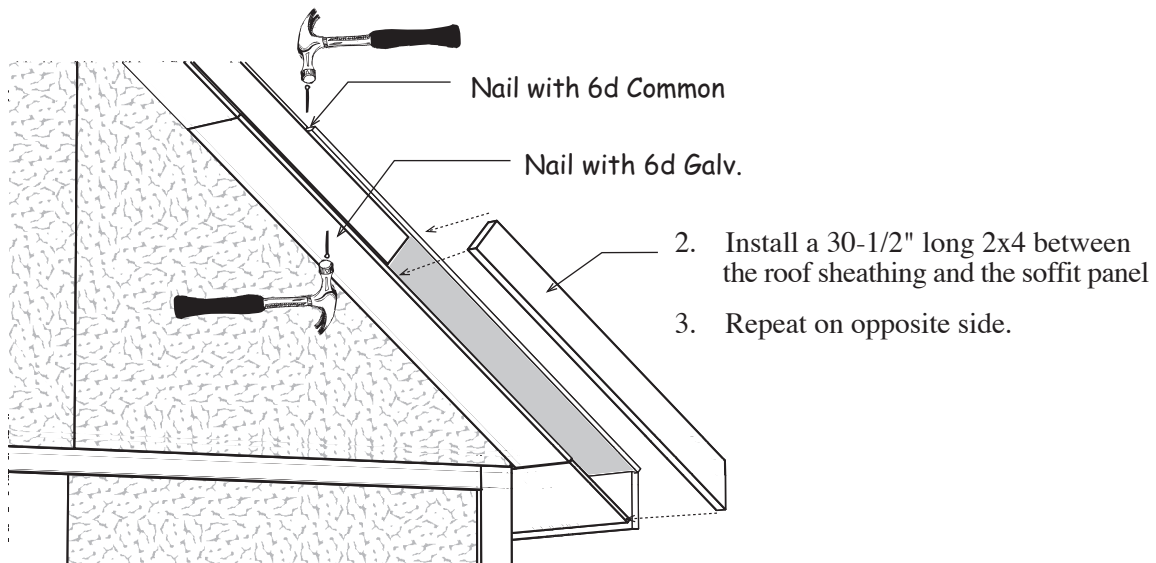

Step 23 Install Door Flashing

1. Locate (2) two 3-1/2" wide x 5" metal flashing and bend along width to 90 degrees. Install at each corner of the door opening. These will be covered in the next steps.
2. Install the galv. door sill over flashing in the center of the door opening. Use 1-1/4" pan head screws along the front edge. If installing on a slab use concrete anchor screws (not included).

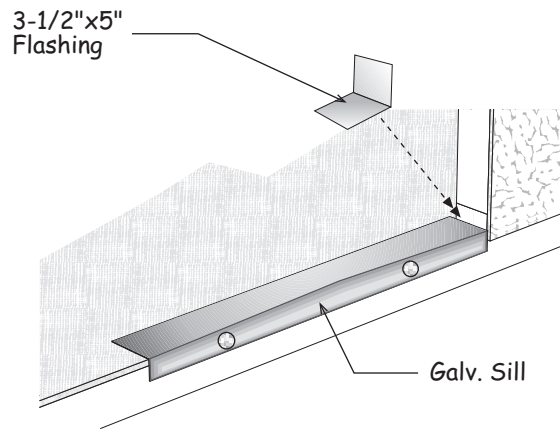

Step 24 Install Pocket Doors Track

1. Install a 72" long Track Support Assembly 82-3/4" from the floor. **Important:** measure from the bottom of the 2x3 on the support assembly to the floor. Insure the notched end of track is center of door opening. Use 2-1/2" screws.

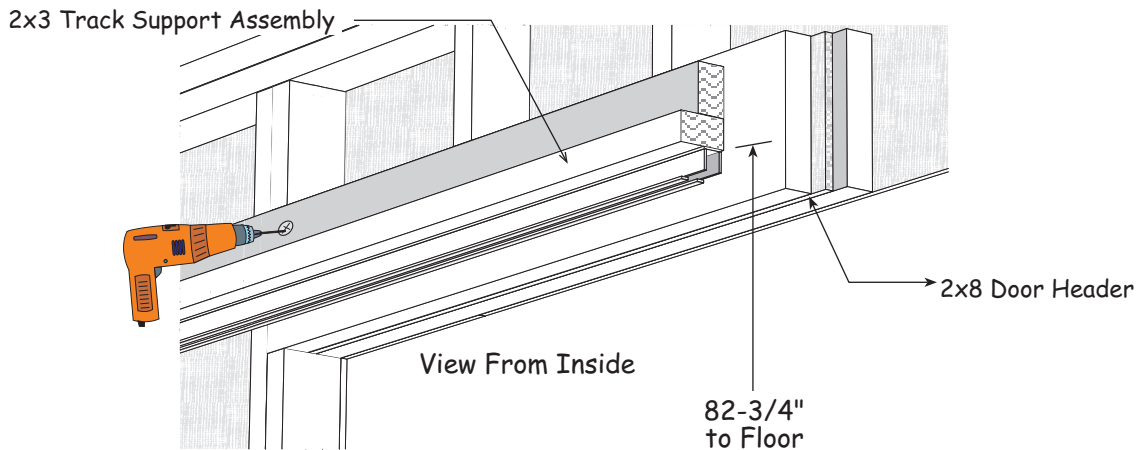

2. Install the other track support assembly.

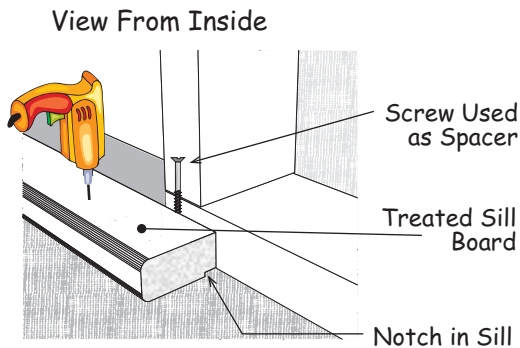
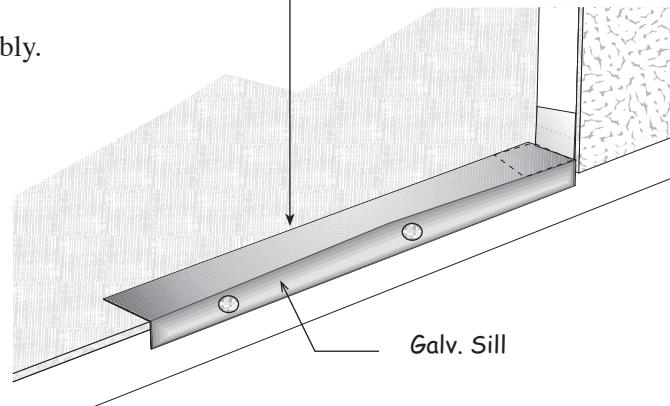

5. Install the treated door sill behind the door opening. There needs to be a space between the treated sill and the inside wall. To position the sill, insert a 2-1/2" screw between the treated sill and the inside wall as a spacer. Screw the sill to the floor with (6) six 2-1/2" long screws. Remove the screw used as a spacer.

 *Building Tip; run a bead of caulking where flashing, treated sill and aluminum sill meet to prevent moisture from penetrating.*

Step 25 Install Front Gable Trim and Door Trim

1. On front gable install (2) two 38-3/4" long 1x6 trim boards with angle cut on one end over the 2x4 boards at the peak. Trim should be flush with the top of the OSB roof sheathing. Use 6d galv. nails.
2. Finish with (2) two 72" long 1x6 trim boards.
3. Repeat to install gable trim on the rear gable.

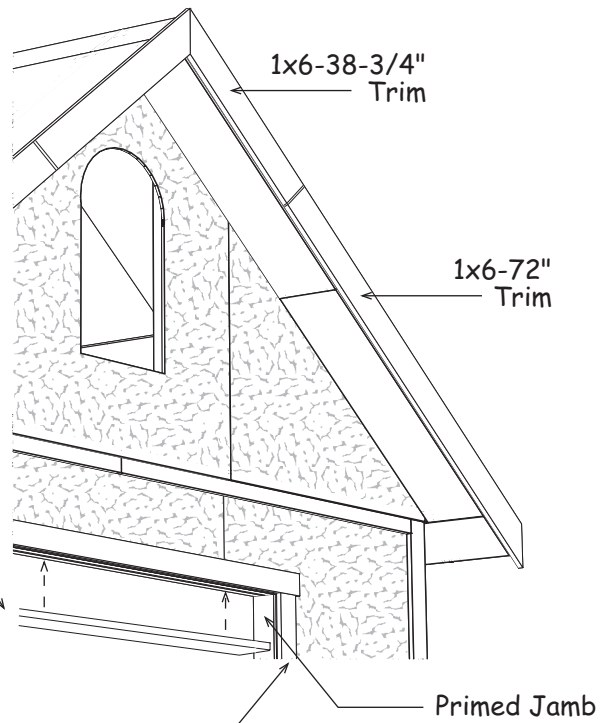

4. Install a 3-7/8" x 72" primed jamb material on the top of the door opening, flush with the front wall siding. Use 6d galv. nails.
5. Locate (2) two 3-7/8" x 79-5/8" primed jamb material and install on the sides of the door opening, flush with the front wall siding.
6. Locate (2) two 80-3/4" long 1x4s and install flush with door jamb and top of door opening.
7. Install an 81-3/4" long 1x4 trim board, *this board has angle cuts on both ends*, centered across the top of the door opening.

Step 26A Install Doors

1. Select the door with the siding and trim board extending past the 2x4 frame, *see detail below*. Standing on the inside of building slide the rollers on the left side track as shown below.

If it is necessary to adjust the door height one or both door carriers can be adjusted. Loosen screws that secure carrier(s) to the door. Adjust door so the aluminum angle, on the bottom of the door, does not rub on the treated threshold. Tighten the screws.

Tip: Inserting a screw, *shown below*, will prevent the doors from falling through the opening between the track, if the door is opened too far.

IMPORTANT:

DO NOT install track rollers in the space between the Track Legs.

Install the track rollers on the inside track leg.

See detail below.

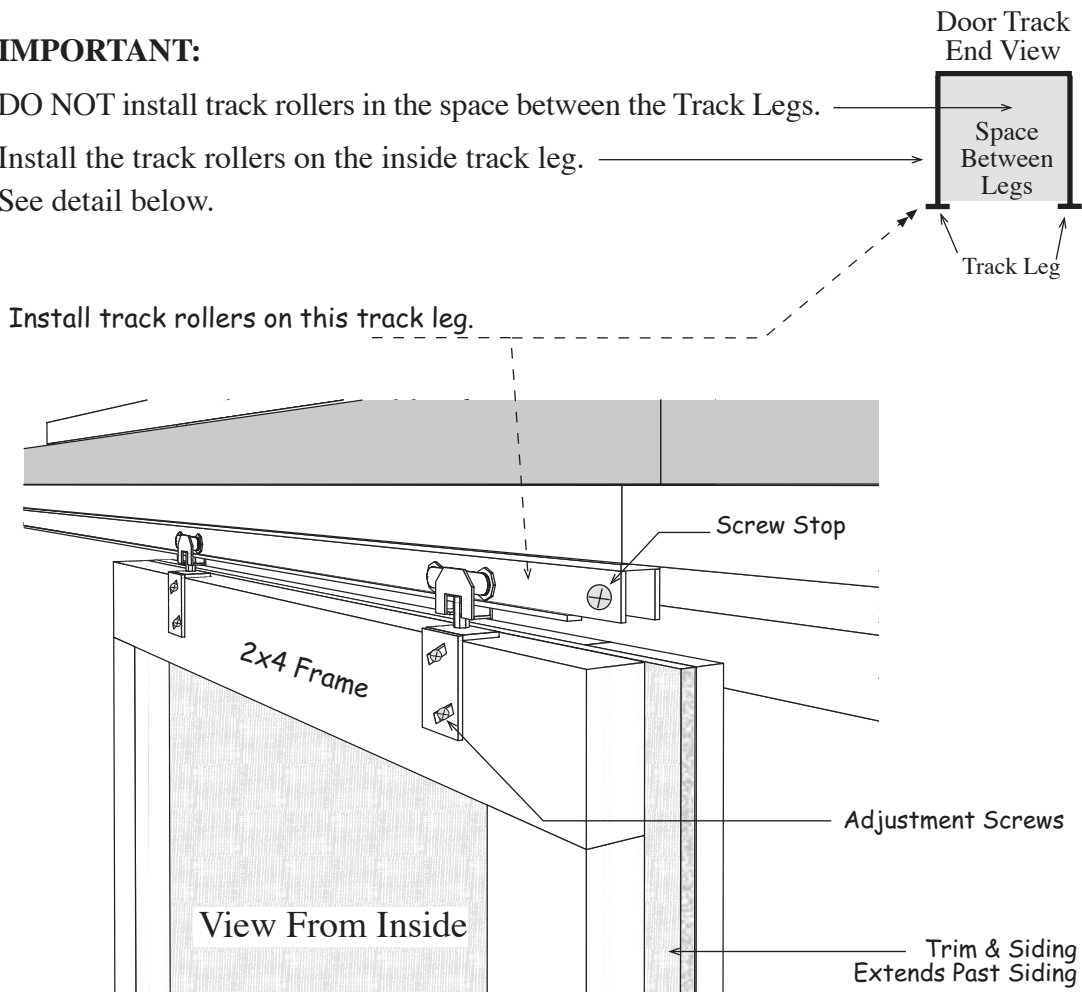

Step 26B Install Doors continued

2. Hang the other door. From the inside of building close both doors. On the right door, install a sliding door latch at the bottom of 2x4 frame. You will need to drill a hole in the floor for the round shaft to drop into.
3. Install a metal plate to the lower back of other door. The angled end will keep both doors aligned when closed.
4. From the outside install the door handles and locking door hasp on the outside of the doors.

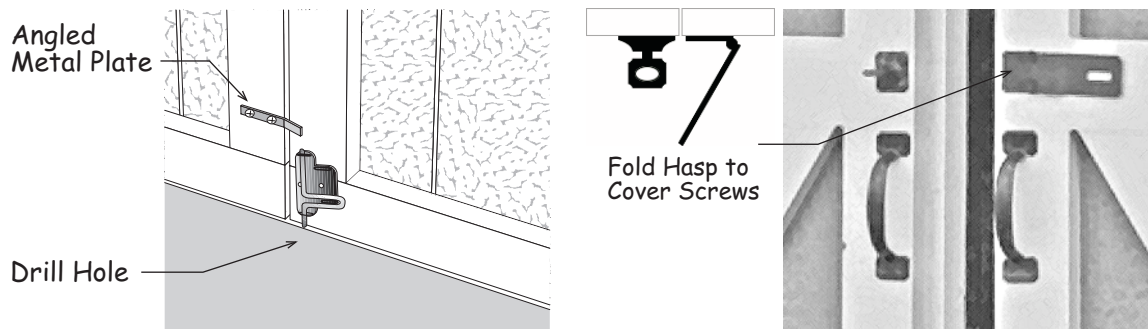

Install Roofing — Not Supplied in Kit

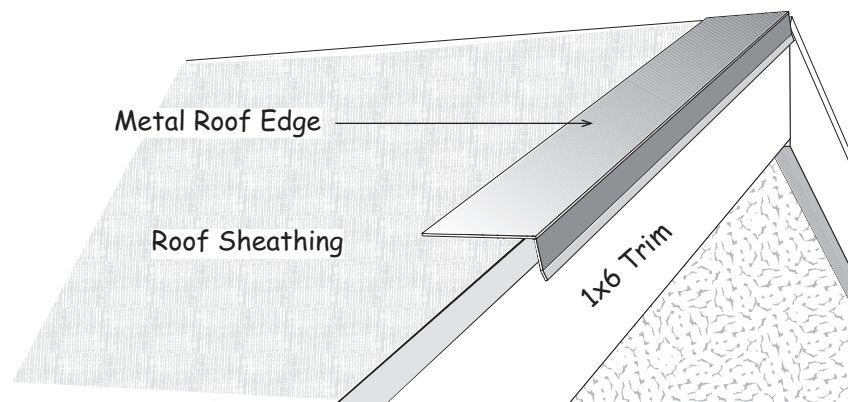

1. Install metal roof 'drip' edging along the perimeter of the roof.
2. Install felt paper and shingles according to manufacture's instructions.

Optional Roof Covering

13	bdl.	Roof Shingles
9	pcs.	Roof 'drip' Edge-10'

Material List for Wood Pocket Doors	
2	36" x 79" Wood Doors w/ Primed Siding
2	Boards w/ Alum. Track Attached
1	Treated Wood Threshold
1	Galvanized Door Sill
1	Door Trim 1x4 81-3/4"
2	Door Trim 1x4 80"
1	Door Jamb 3-7/8" x 72"
2	Door Jamb 3-7/8" x 79 - 1/4"
4	Track Rollers with Brackets
1	Swivel Door Latch
2	Door Handles
1	Sliding Latch
1	Flat Steel Bar Door Guild
2	3" x 5" Galv Flashing
4	1-1/4" Pan Head Screws for Door Sill
16	2-1/2" Wood Screws / square bit

Qty.	Material Shipped in 4' Extension Kit	
4	Truss Rafters	2x4 77-3/8"
2	Trim Boards	1x3 48"
2	Trim Boards	1x6 48"
2	Ridge Block	2x4 18-1/2"
2	Pre-built Truss Assemblies - lefthand	
2	Pre-built Truss Assemblies - righthand	
2	Primed Soffit Boards 3/8" x 9-3/4"x 48-3/4"	
2	OSB Sheathing	7/16" x 9-3/4"x 48"
4	Wood Gussets	15-3/4" x 27-1/2"
4	Joist Hangers	2x4
1	lb. 10d Sinkers	
1	lb. 6d Common Nails	
1	lb. 6d Galv. Nails	

Qty.	Supplied by Local Supplier	
42 pcs.	2x4	Pre-cut Wall Studs
17 pcs.	2x4 - 12'	Wall & Tie Plates
2 pcs.	2x4 - 8'	Wall & Tie Plates
8 pcs.	2x4 - 10'	Wall & Tie Plates
2 pcs.	2x8 - 8'	Door Header
15 pcs.	Exterior Siding	4x8
12 pcs.	OSB Sheathing	4x8

Qty.	<i>Material Packaged on Pallet</i>		
20	Truss Rafters	2x4	77-3/8"
7	Ridge Block	2x4	18-1/2"
6	Gable Overhang	2x4	30-3/4"
4	Gable Rafters	2x4	32-3/8"
2	Gable Plates	2x4	49-1/2"
4	Gable Studs	2x4	50-3/4"
10	Trim	1x3	72"
4	Trim	1x3	27"
8	Trim	1x4	72"
4	Trim	1x4	27"
2	Trim	1x6	75"
4	Trim	1x6	72"
4	Trim w/Angle Cut	1x6	72"
4	Trim w/Angle Cut	1x6	38-3/4"
2	Pre-built Gable Frames - lefthand		
2	Pre-built Gable Frames - righthand		
7	Pre-built Truss Ends - lefthand		
7	Pre-built Truss Ends - righthand		
2	Pre-cut 46" High Gable Siding - tongue edge		
2	Pre-cut 46" High Gable Siding - lap edge		
2	Pre-cut 66" High Gable Siding - center		
2	Pre-cut Siding 20" x 48-3/4"		
	1 Not used in this model		

Qty.	<i>Material Packaged on Pallet</i>		
1	7/16"	48" x 24" OSB Sheathing	
2	7/16"	48" x 51" OSB Sheathing	
1	7/16"	48" x 48" OSB Sheathing	
2	7/16"	48" x 75" OSB Sheathing	
4	7/16"	9-3/4" x 48" OSB Sheathing	
2	7/16"	9-3/4" x 51" OSB Sheathing	
2	7/16"	9-3/4" x 59-1/4" OSB Sheathing	
4	7/16"	3-1/2" x 24" OSB Sheathing	
2	7/16"	7-1/4" x 48" OSB Header Fillers	
14	3/8"	Soffit Boards 9-3/4" x 48-3/4"	
6	3/8"	Filler Boards 2" x 48-3/4"	
4	lbs.	10d	Sinkers
5	lbs.	6d	Galv. Nails
7	lbs.	6d	Common
1	lb.	1-1/2"	Hanger Nails
25	2-1/2"	Wood Screws	
14	2x4	Joist Hangers	
50	Plyclips for Roof Sheathing		
14	Wood Gussets	15-3/4" x 27-1/2"	
16	Wood Gussets	24" x 11"	
4	Wood Gussets	5-3/4" x 14"	
2	Wood Gussets	5-1/2" x 27-3/4"	
12	1x4	Jig Blocks 18"-10" long approx.	
2	3/8"	Gauge Blocks 3" x 8"	