



Best Barns USA Assembly Book

Revised November 13, 2023



the Meadowbrook-R

16' x 10'

Manufactured by RBS Holdings, LLC

205 Arlington Drive

Greenville, PA 16125

This manual is copyrighted. Under the copyright laws, this manual may not be copied, in whole or in part, without consent from RBS Holdings, LLC © Copyright 2022

IMPORTANT INFORMATION ABOUT YOUR KIT

Thank you for purchasing our kit. Please read the following information before beginning construction. Always check with your local HOA or building code office for any requirements or restrictions.

Floor: Wood flooring is sold optionally. You may choose to build your own or pour a cement pad.

Always wear safety glasses when cutting or nailing!

| | | | |
|-----------------|----------------------|-----------------|----------------------|
| Tools Required: | Hand or Circular Saw | Level | Safety Glasses |
| | Cordless Drill | Measuring Tape | Dust Mask |
| | Hammer | 6'-8' Ladder(s) | Phillips Screwdriver |
| | Pencil | | Framing Square |

Additional Materials - **Not included in kit:**

Windows are purchased separately

Required: Shingles or metal roofing, Drip Edge, Roofing Nails or Screws, Paint

Optional: Caulk, Ridge Vent

Terminology:

Square - Confirm corners are at 90 degrees
Plumb - Confirm walls and trusses are straight vertically
Wall Plate - Top and bottom 2x4s used to frame walls
Tie Plate - 2x4s connecting wall sections together
Header - Spans top of door opening
OSB - Oriented Strand Board
LAP - Edge of siding that overlaps Tongue
Tongue - Edge of siding that is overlapped

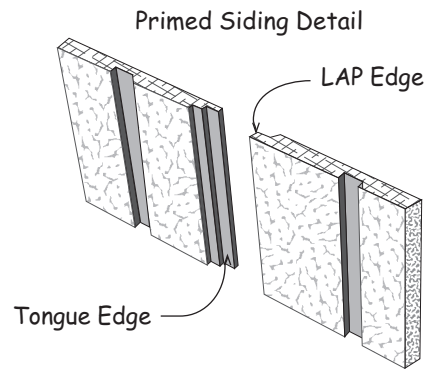

Organize:

Unpack all items & organize according to size and type. This will make items easier to find when instructed.

Review the parts list on the back page. Should there be missing items or sub-par material contact Best Barns Customer Service.

DO NOT discard any material including the pallet until your project is complete.

Assembly:

Review all instructions before you begin. Please follow steps carefully and in sequence for successful results.

If you have any questions we are happy to assist you. Please contact us at:

800-245-1577 - Mon - Fri 8AM - 5PM EST

724-866-4357 - After hours and weekends

Email - questions@barnkits.com

Constructing Details for Deluxe Floor System

Deluxe floors include 4x4 runners, standard floors do not

Foundation size is 10'-0" x 15'-9". Check local building codes in your area, the construction may have to change. For a concrete slab, install sill sealer as a moisture barrier between the concrete and the wall plates. Foam sill sealer can be purchased at home centers in rolls 3-1/2" or wider.

1. Cut joist headers to floor length. See Below.

Layout for 16" on center joist spacing. 'X' marks where floor joist will be placed.

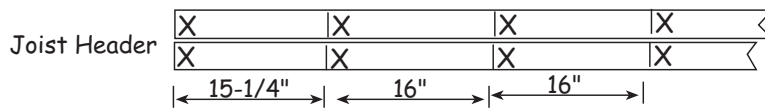

2. Cut 2x4-10' floor joist to 9' - 9". *Treated lumber may be thicker than 1-1/2". Take this into account when cutting the length of floor joists. Shorten joist measurements if necessary to obtain 10'-0" building width.*

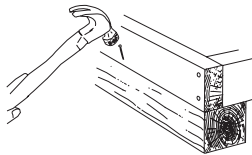
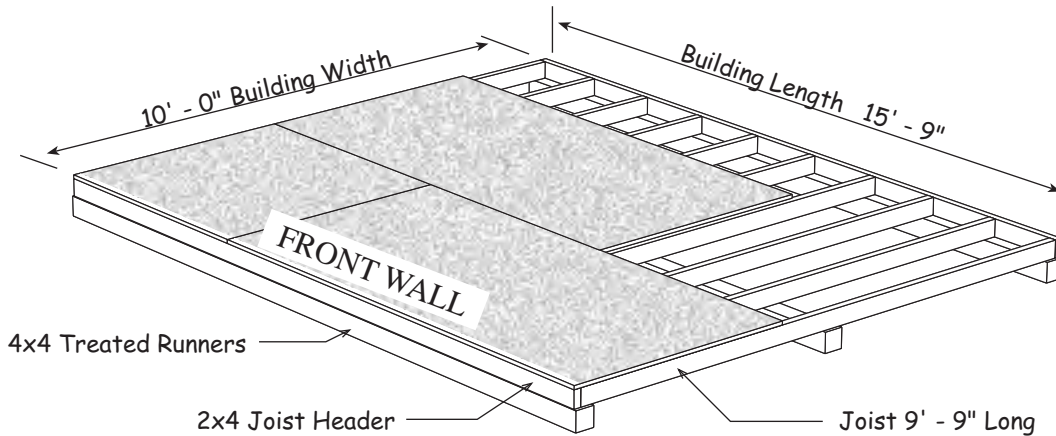

Nail the 2x4s to the 4x4 runners to keep the 2x4 frame from moving.

It is important that the floor be level and square. Before nailing the flooring, measure the floor diagonally (corner to corner). Then measure the opposite corners. These measurements will be the same if the floor is square.

| Material Description | 10' x 16' shed |
|-----------------------|----------------|
| 2x4 Joist Headers | 2 pcs. 16' |
| 2x4 Floor Joist | 13 pcs. 10' |
| 4x4 Treated Runners | 6 pcs. 8' |
| Flooring 5/8" or 3/4" | 5 pcs. 4x8 |
| Screw Floor Nails | 2 lb. 8d |
| Galv. Box Nails | 1 lb. 16d |

Step 1 Assemble Trusses

1. Position (2) two truss halves together so that a 116-1/4" long 2x4 bottom cord may be placed between them.
2. Hold truss parts in place by temporarily screwing 2x4 blocks to the floor. There are short 2x4 blocks supplied in the kit for this purpose. Use 2-1/2" wood screws.
3. Secure the tops together with a wood gusset. Nail the gusset with (16) sixteen 6d common nails. Space nails evenly.
4. Secure the truss bottom legs to the bottom cord with wood gussets. **Note:** You may have to spread the truss bottom to fit the bottom 2x4. Use 12 nails per gusset. Space nails evenly.
5. Assemble (5) five more trusses.
6. Turn trusses over and apply wood gussets to the opposite side.

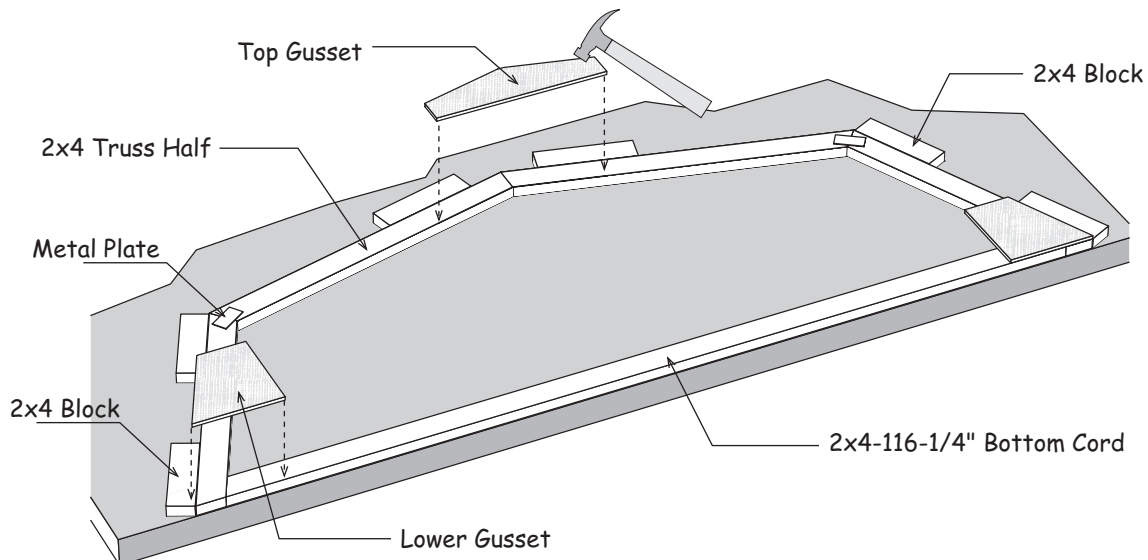

7. Assemble another truss without a bottom cord. Locate wood gussets with a 2x4 block attached to one side.
8. Attach this block/gusset to the bottom of each truss leg. Secure to leg with 6d common nails.
9. Turn truss over and apply gussets.

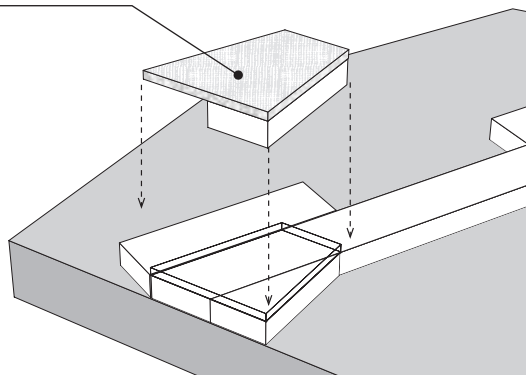

Do Not remove blocks from floor until **Step 2** is completed.

Step 2 Assemble Gable without Loft Door

1. **IMPORTANT: Do no use truss halves to make gables.** Place (2) two 47" long, (2) two 38" long 2x4 gable rafters and a 116-1/4" bottom cord in the truss jig. Secure at knee with 1"x4" drive-on plates. Secure bottom cord with gussets.
2. Select a 42" long 2x4 center stud and cut to fit between ridge and bottom cord.
3. Install (2) two 21-1/2" and (2) two 34-1/4" with angle cut on one end. Secure 2x4 gable studs to the truss with (9) nine 1"x4" metal plates at top and bottom.

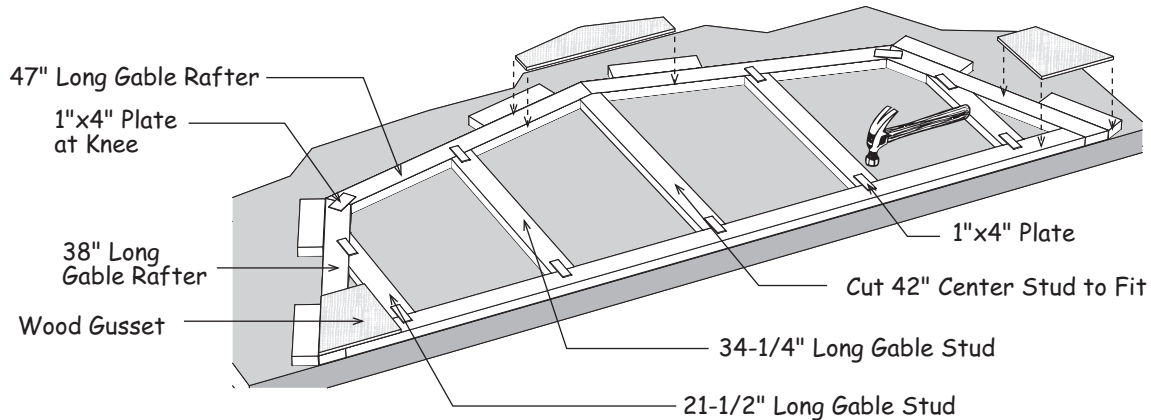

4. Screw (3) three 16" long 2x4 blocks flush with bottom of the 2x4 bottom cord. One on each end and one in the center. Use (2) two 2-1/2" screws.

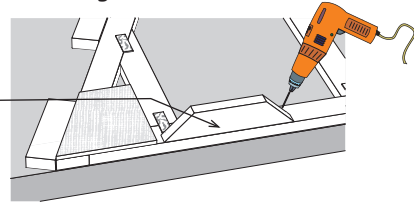

5. Turn the gable over. Locate pre-cut gable siding. Starting from left install the siding extending 3/4" below the bottom 2x4. Insure the siding does not extend above the top frame. Use 6d galv. nails spaced 12" apart.

 *Tip: To prevent gable studs from being knocked loose when nailing siding, lay 2x4 OSB sheathing, supplied in kit, under the studs.*

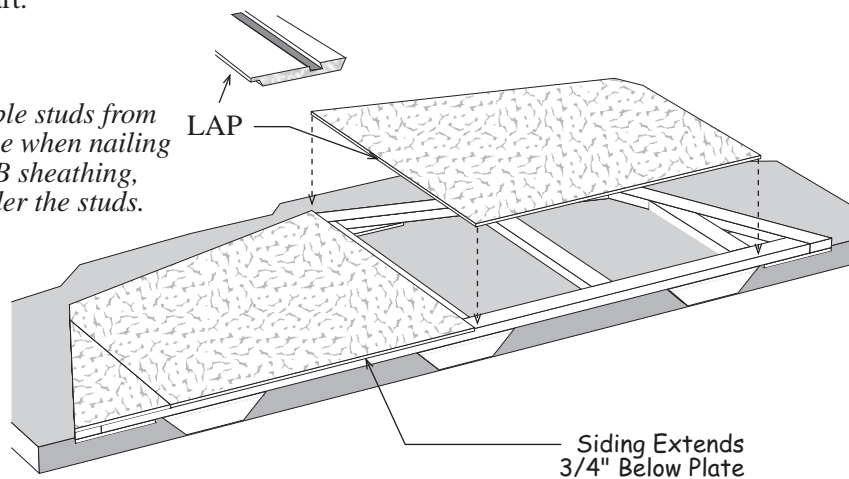

Step 3 Install Gable Overhang & Trim

1. Apply 47" long 2x3 boards to the gable. Install boards flush with the top of the gable frame. Use 10d sinkers.
2. Install a 42-1/4" long 2x3 at the sides of the gable, flush with the frame. Board will extend below siding.

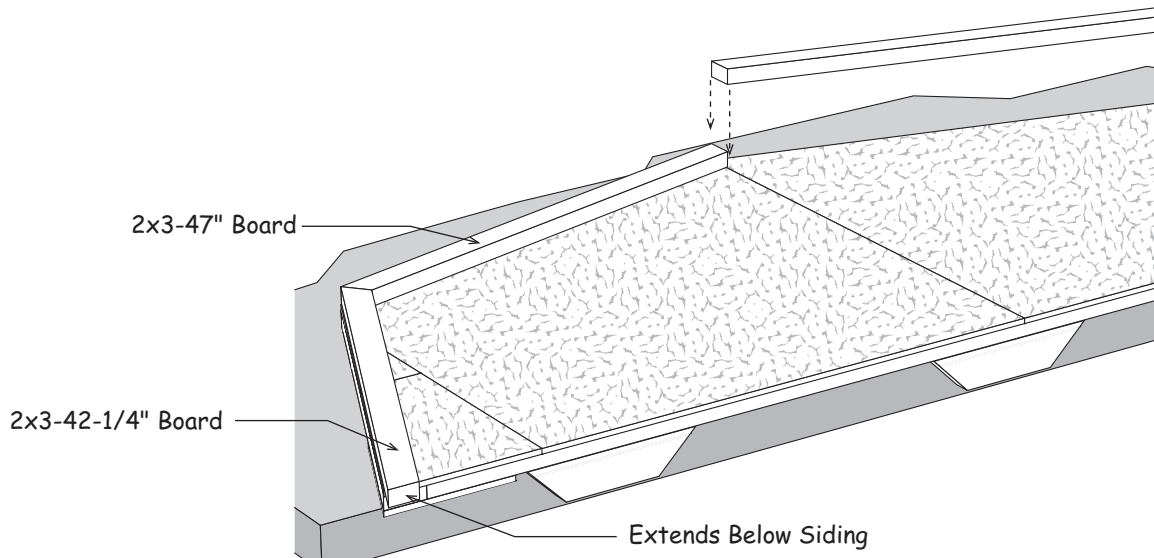

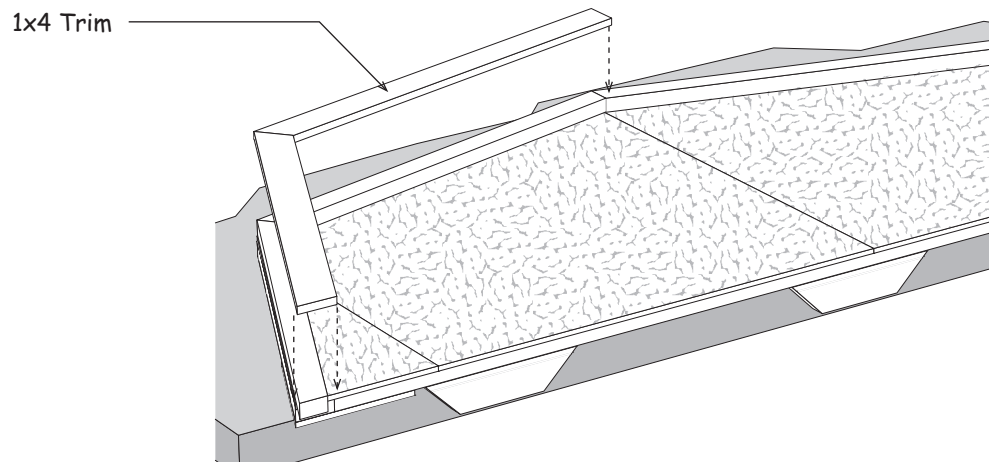

3. Apply 1x4 trim to gable. Install a 47" long 1x4 at the top of the gable. Install the 1x4 gable trim extending 1/2" above the siding on the gable. When installed later, the roof sheathing will be flush with the top of the trim. Use 6d galv. nails spaced 8" apart.
4. Install a 42-1/4" long 1x4 at the sides of the gable.

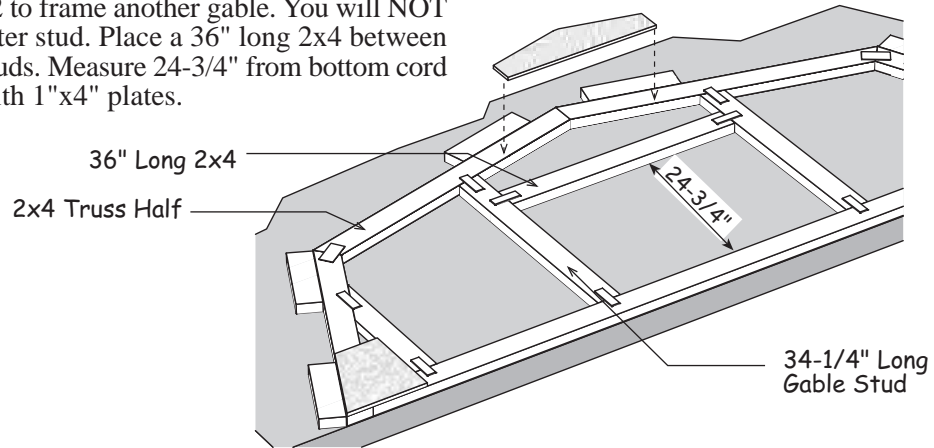

Step 4 Assemble Roof Gable With Loft Doors

1. Repeat Step 2 to frame another gable. You will NOT use a 42" center stud. Place a 36" long 2x4 between the 34-1/4" studs. Measure 24-3/4" from bottom cord and secure with 1"x4" plates.



 If you don't need loft access from the outside, attach loft door frames to the gable to create a decorative look and weather tight storage area.

2. Turn the gable over. Lay out the first (2) two pieces of siding on frame. **Important: Do not nail to frame.** Mark and cut so siding is flush with top and left side of opening. Cut to bottom of siding below gable plate. Nail first two pieces of siding to frame. Lay out next siding panel, do not nail, and repeat cut for right side door opening. Nail last two pieces of siding to frame.

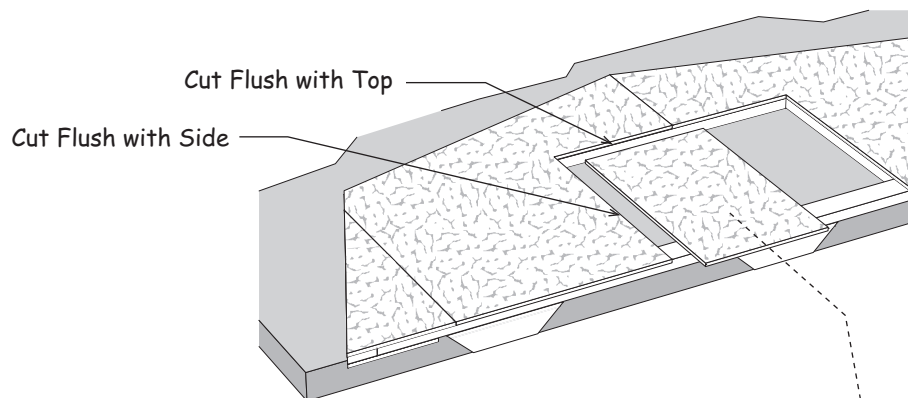

3. Assemble the loft doors. The loft door frames are temporarily held together with corrugated fasteners, this is the back side of the door frame. Place the doors on level surface, face side down. Cut the siding from above step to the size of the door frame. Secure the siding panel to the frame with 1" screws provided.

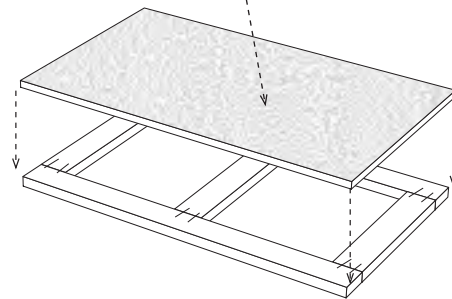

Step 5 Install Gable Trim & Loft Doors

1. Apply 47" long 2x3 boards to the gable. Install boards flush with the top of the gable frame.
2. Install a 42-1/4" long 2x3 at the sides of the gable, flush with the frame.
3. Install 29-1/4" long 1x3 trim boards on each side of the loft door opening. Install a 43" long trim board across the top. Use 6d galv. nails.
4. Install loft doors using 4" hinges and 1-1/4" long hinge screws. The screws have a square head. The bit is packed with the screws. Install barrel bolts to the inside top of the doors to secure doors when closed. When door is closed mark where bolt will hit 2x4 gable frame. You will need to drill a 1/4" hole into the underside of the 2x4.

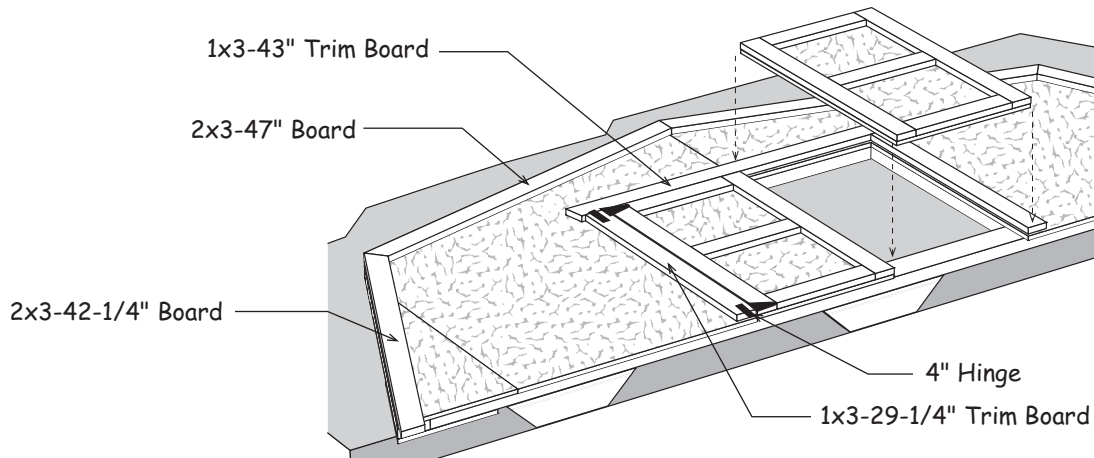

5. Apply 1x4 trim to gable. Install a 47-1/2" long 1x4 at the top of the gable. Install trim flush with the top of the gable frame. Use 6d galv. nails.
6. Install a 43" long 1x4 at the sides of the gable, flush with the frame.

Step 6 Cut 2x4 Wall Plates for Front Wall Assembly

1. Locate (2) two 68-1/2" long 2x4s. Cut each to a length of 37-1/2". Position together as shown below. Mark line and Indicate with 'X' marks, where the wall studs will be located.
2. Position (2) two 80" long 2x4 boards together as shown below. Mark line and Indicate with 'X' marks, where the wall studs will be located.

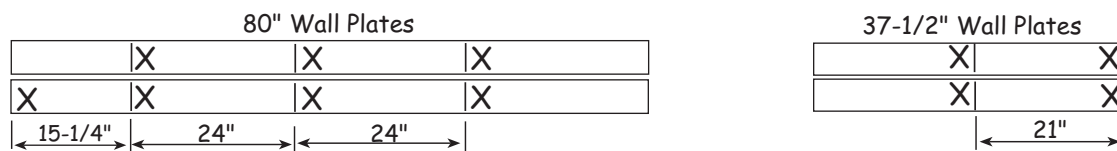

Step 7A Assemble Front Wall Panels

1. Cut (2) two 2x4-6' to a length of 69-1/2".
2. Assemble a door header support by nailing a 69-1/2" long 2x4 to a 72" long 2x4. Use 10d sinkers.
3. Assemble another header support.
4. Install 72" long wall studs between the wall plates from **Step 6**. Install 2x4 studs over the 'X' marks. Install a header support as shown on each wall frame. Use (2) two 10d sinkers at the each end of stud.

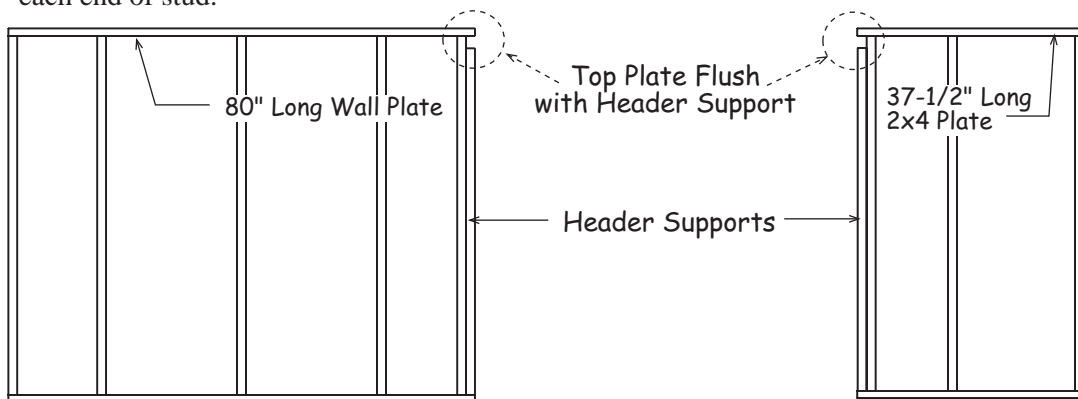
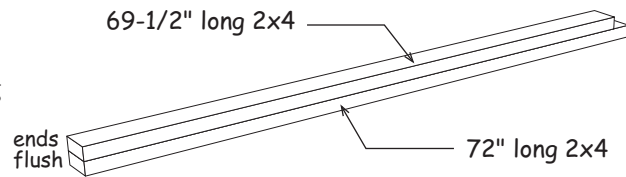

 To offset the doors to the left end of the wall, turn frames over before applying the siding.

5. Install a 70-1/2" long 2x6 as a tie plate across the top of the wall. Install the 2x6 extending 3-1/2" beyond wall frame. Use 10d sinkers spaced 6" apart.
6. Locate (2) two 16" wide x 77-1/4" long siding panels. Cut these panels to a length of 75-3/4".
7. Measuring from the 'tongue' edge, cut a full width x 75-3/4" panel to a width of 19-1/2". Save cut off to be used later. Install panel so the cut edge extends 3-1/2" beyond the end of the 80" long wall frame. Siding will be flush with the top of the 2x4 plate and extend 3/4" below the bottom plate. Use 6d galv. nails spaced 12" on center.
8. Install a full width x 75-3/4" siding panel.
9. Install the 16" panel, with the 'LAP' edge. Cut edge should be flush with header support.

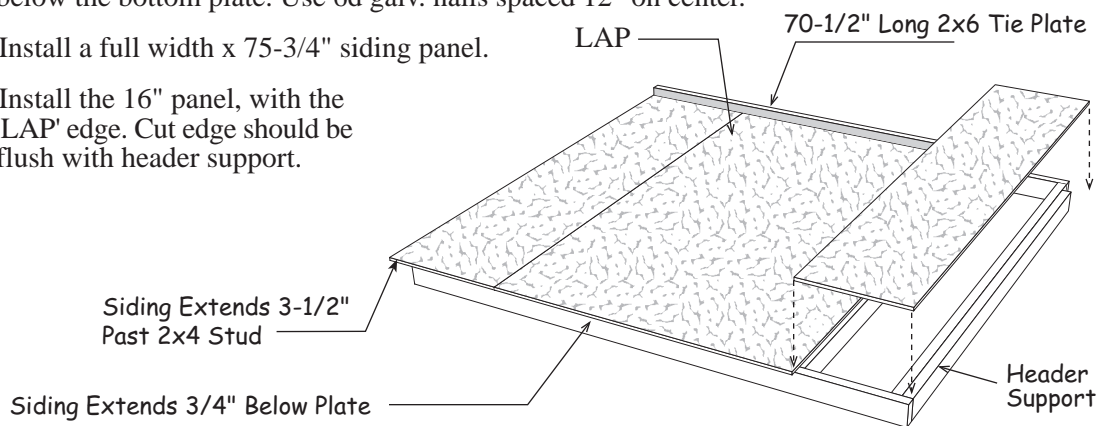

Step 7B Assemble Front Wall Panels Continued

10. Locate the 16" panel, with the 'tongue' edge and install this panel with the cut edge flush with the 2x4 header support. Install siding flush with the top of the 2x4 top plate.
11. Cut the leftover siding to a width of 25" and install as the last panel. The siding will extend 3-1/2" beyond the end of the wall frame.

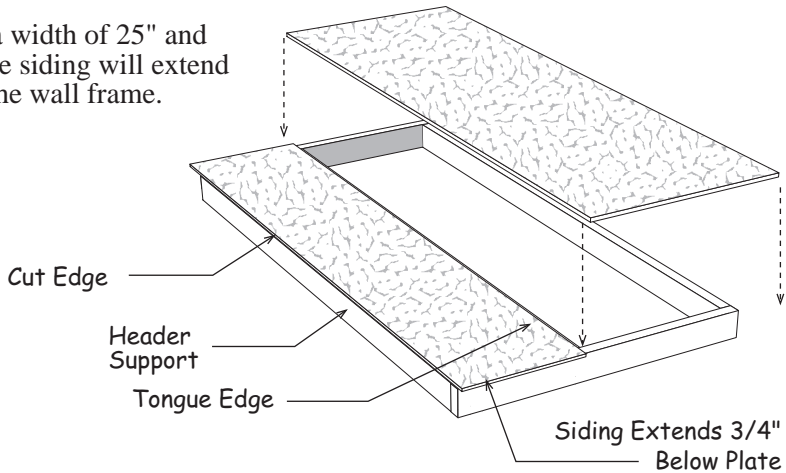

Step 8 Assemble End Wall

1. Position (2) two 2x4-10' boards together and indicate with 'X' marks, where the wall studs will be located.
2. Install 72" wall studs between the top and bottom plates.
3. Install (2) two 56-1/2" long 2x4 as tie plates over the top plate. The 2x4s will be 3-1/2" short of the end of the wall frame.

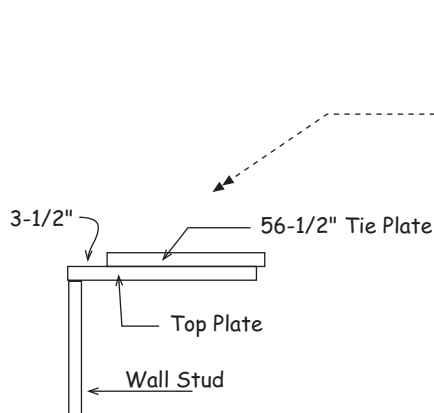
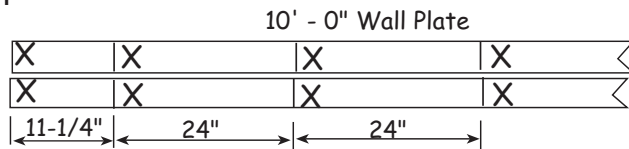

4. Square wall frame. Measure diagonally (corner to corner).

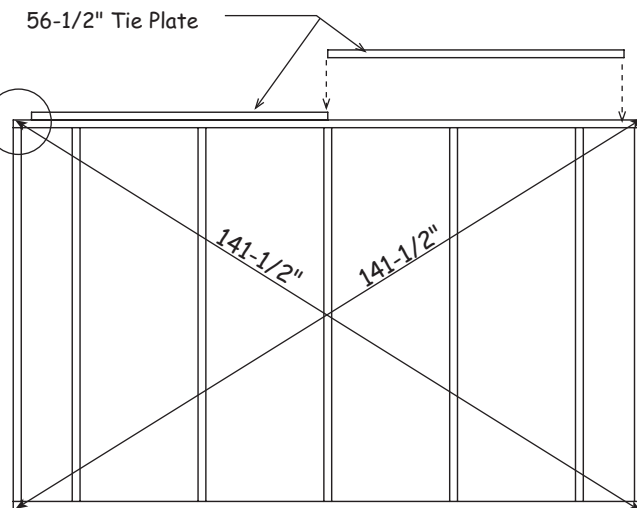

Step 9 Apply Siding to End Wall

1. Locate a 36-3/4" x 77-1/4" siding panel with the 'tongue' edge. Install the siding panel on the left corner, with the cut edge flush with the end of the wall and flush with the top of the 2x4 tie plate. The siding should extend below the bottom plate.
2. Install a 48-3/4" x 77-1/4" siding panel in the center of the wall frame.
3. Install a 36" x 77-1-4" panel with the 'LAP' edge last.

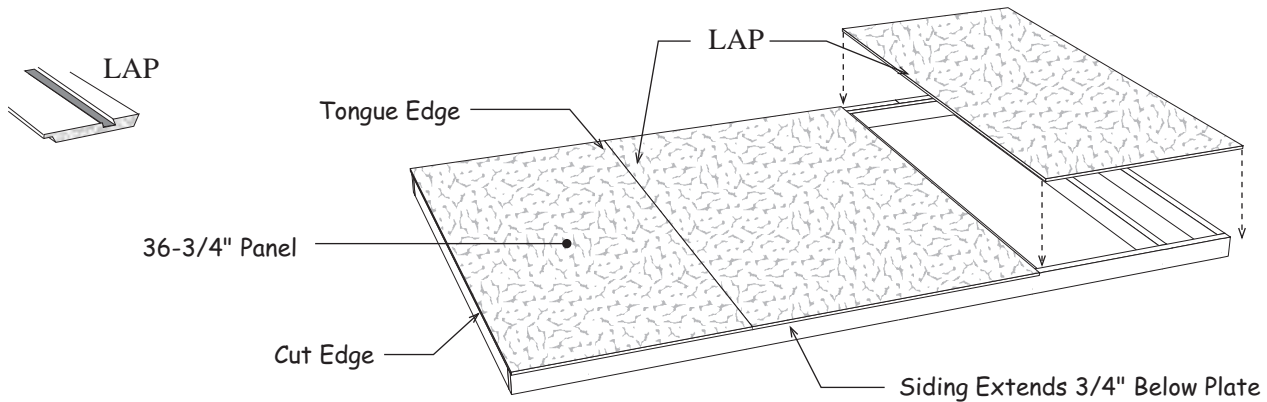

Step 10 Assemble Another End Wall

1. Repeat **Step 8** to assemble another end wall frame
2. Locate the 12-3/4" panel, with the 'tongue' edge. Install this siding panel with the cut edge flush with the end of the wall frame. Install siding flush with the top of the 2x4 wall plate.
3. Install (2) two full width siding panels in the center of the wall frame.
4. Install the 12" siding panel flush with the end of the wall frame.

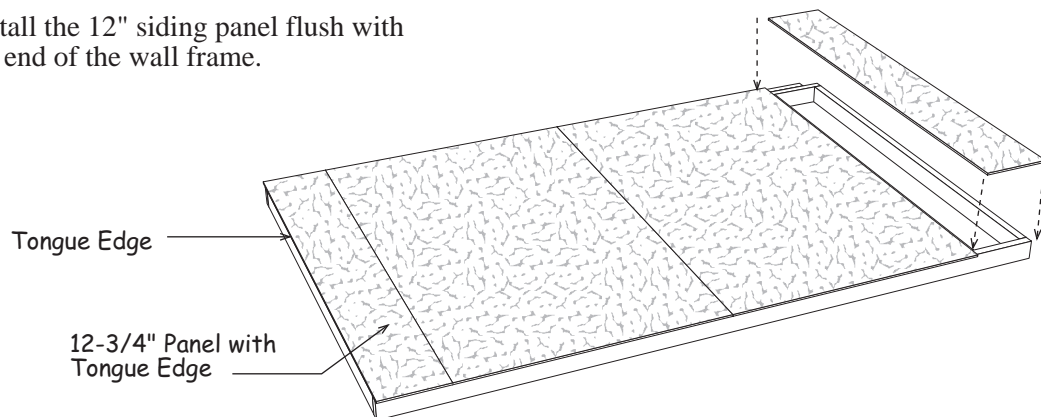

Step 11 Assemble Back Wall

1. Position 68-1/2", 48", and 65-1/2" long 2x4 boards together and mark where the wall studs will be located. Mark the ends that will butt together with the letters 'A', 'B' and 'C'.

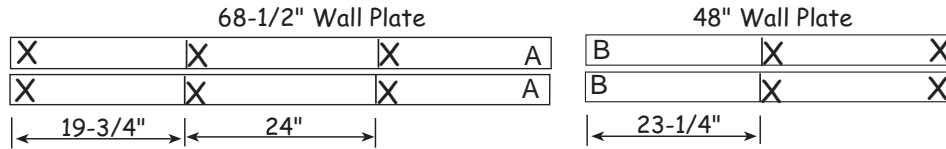

2. Install 72" wall studs between the top and bottom plates. Assemble frames and nail together with 10d sinkers.
3. Install a 48" and (2) two 70-1/2" long 2x6 boards as tie plates over the top plate. The 2x6s will extend 3-1/2" beyond the ends of the wall frame.

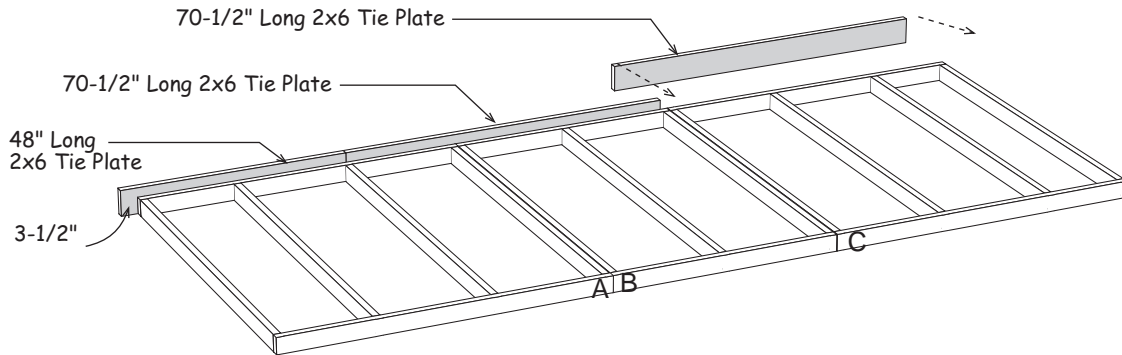
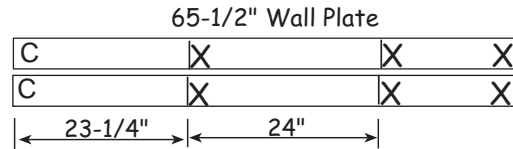

4. Square wall frame. Locate (4) four 75-3/4" long siding panels. Install the first siding panel with the 'LAP' edge extending 3-1/2" beyond the wall frame.
5. Install (2) two full width siding panels in the center.
6. Cut the last siding panel to extend 3-1/2" beyond the last wall stud. *Tip; it will be easier to handle this wall if you install the last siding panel after the walls are set.*

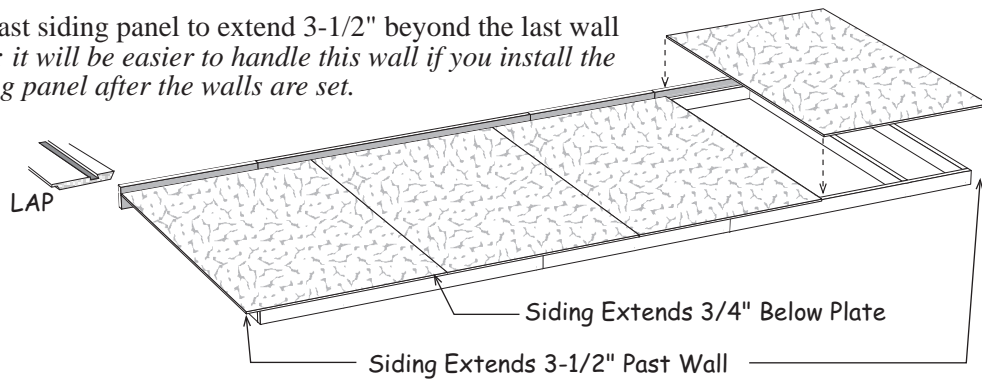

Step 12 Set Lower Walls

 **Front and back walls set inside end walls.**

1. Secure wall panels together at the corners. Use (4) four 10d coated nails per corner. Nail wall panels to the floor. Nail through the bottom plate. Space 10d sinkers 24" apart.

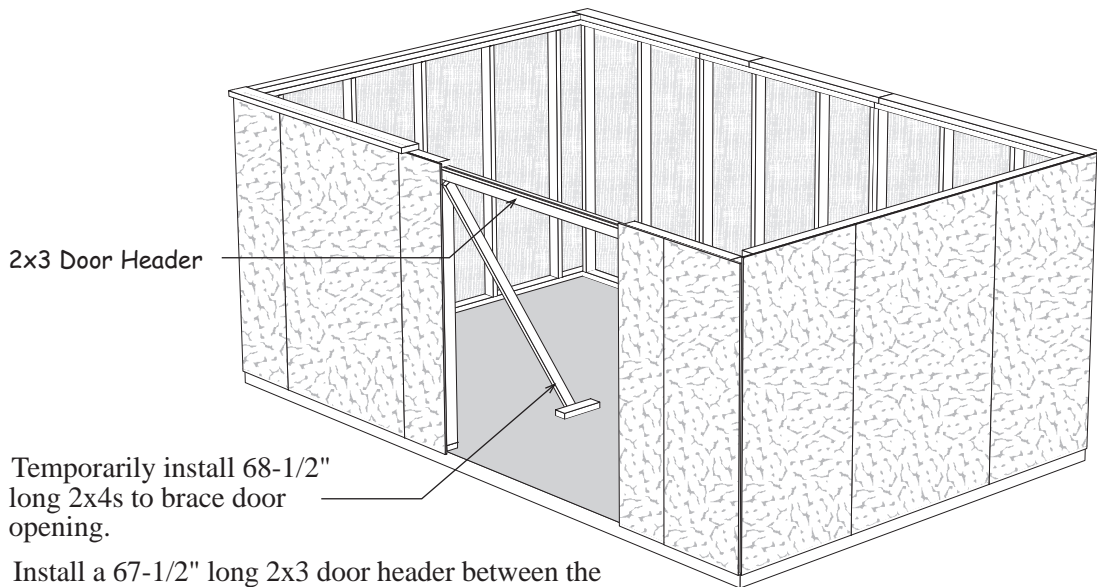

2. Temporarily install 68-1/2" long 2x4s to brace door opening.
3. Install a 67-1/2" long 2x3 door header between the front wall panels. Secure header with 10d sinkers.
4. Cut a 65-1/2" long 2x4 to fit over the door header, between the front wall plates. Secure with 10d sinkers.
5. Install 70-1/2" and 48" long 2x6 over the 2x4 wall plates. Secure with 10d sinkers.

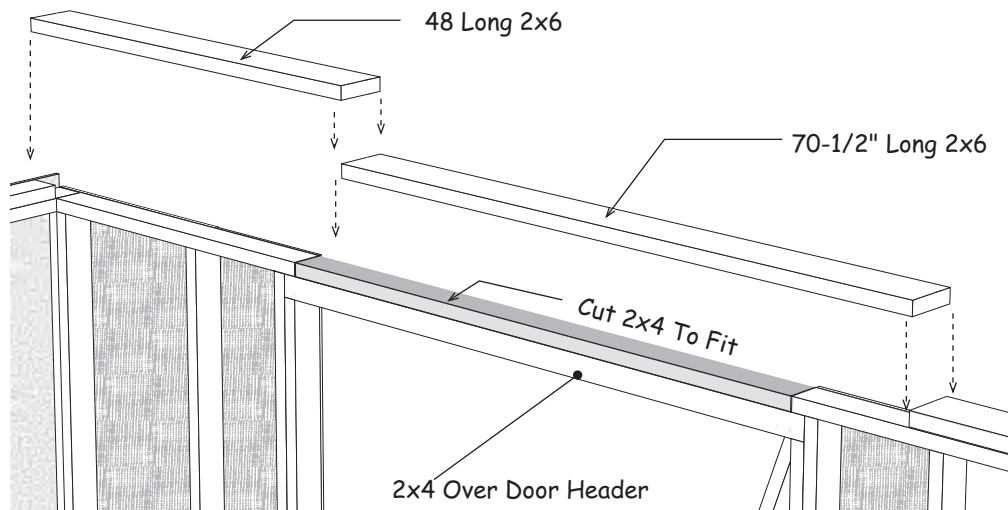

Step 13 Install Trim

1. Locate (2) two siding panels that are 32" wide x 6" in height. Cut these panels to a height of 4-1/2". Install these siding panels over the door header. Siding will extend below header.
2. Install (2) two 1x4-72" boards along each side of the door opening, flush with the bottom edge of the siding. Tack these boards with a couple nails; you may want to move the trim later when you install the doors. Use 6d galv. nails.
3. Install a 1x3-72" board across the top of the side trim.

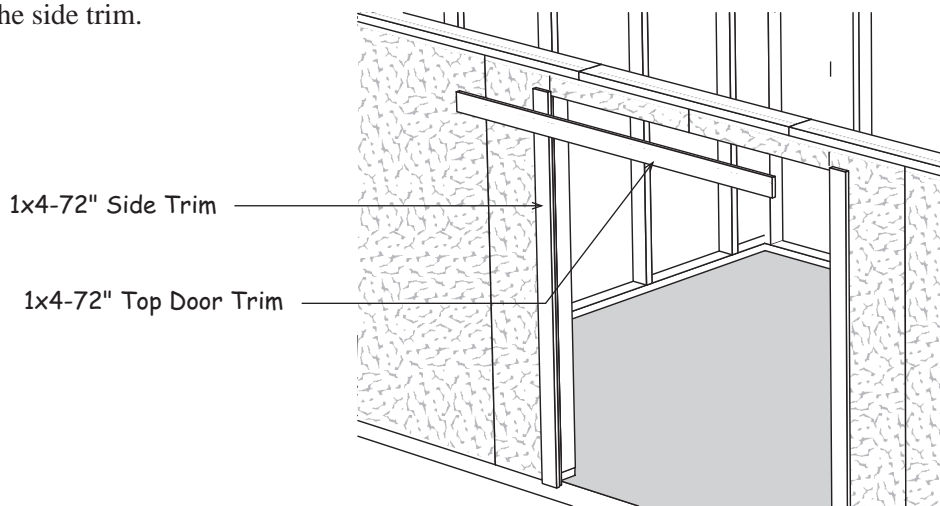

4. Install (2) two 1x3-62" long trim boards flush with the top of the front wall. Use 6d galv. nails.
5. Install 1x4-75 3/4" trim boards at the corners of the front and back. Install the trim flush with siding on the end wall.
6. Install 1x4x74-3/4" trim boards at the corners of the front wall.

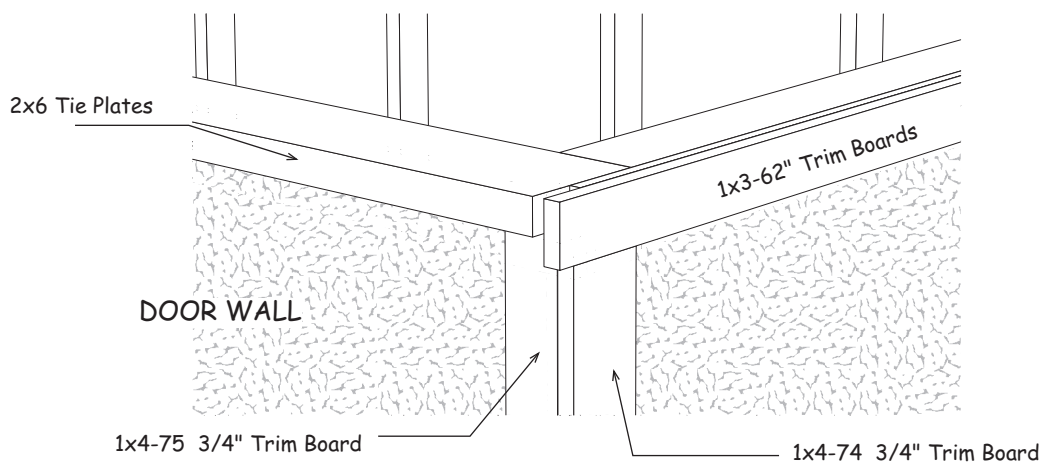

Step 14 Set Left Gable

Install the gable on the left end wall. The gable siding will extend over the 1x3 trim on the lower wall. **NOT behind the trim!** Secure gable to wall by nailing through the gable blocks with 10d sinkers. Nail siding along the 1x3 trim board with 6d galv. nails.

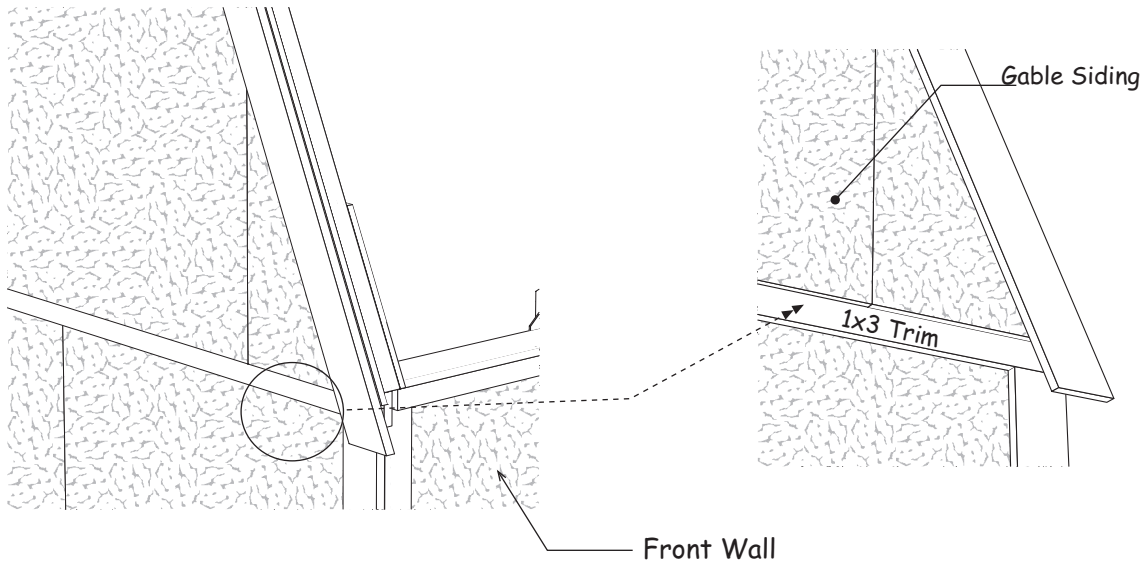

Step 15 Set Trusses

1. Layout the truss spacing on the front wall. Start at the left corner of the building. Measure from the inside face of the wood gusset when marking the location of the first truss. **See next page.**
2. Locate the truss hangers, there are left and right hangers. Select the right hangers.
3. Using 1-1/2" hanger nails, install the right hangers to the 2x6 tie plate. The top hanger flange should line up with the 'X' mark.

Important: When marking the back wall, use the left hangers and place the 'X' mark on the same side of the line so your trusses are parallel when they are installed.

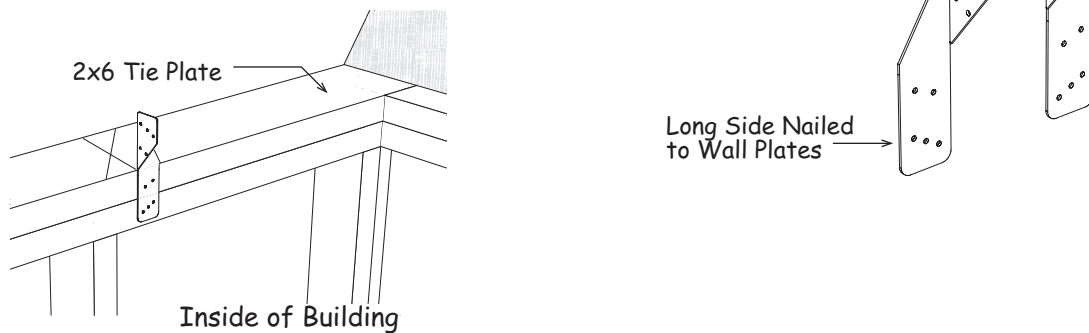

Step 16 Set Trusses Continued

4. Install the trusses over the 'X' marks. Install hanger to the opposite side of the trusses. Secure truss to metal hangers using 1-1/2" hanger nails.

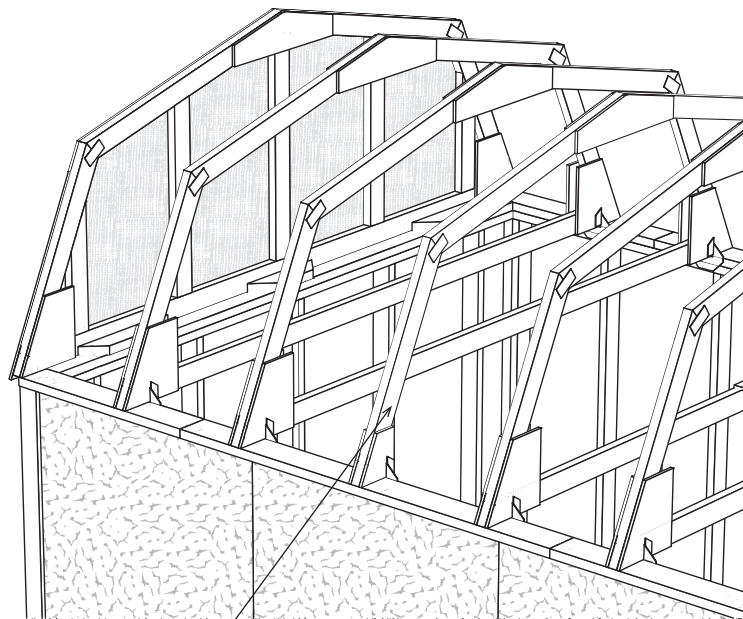
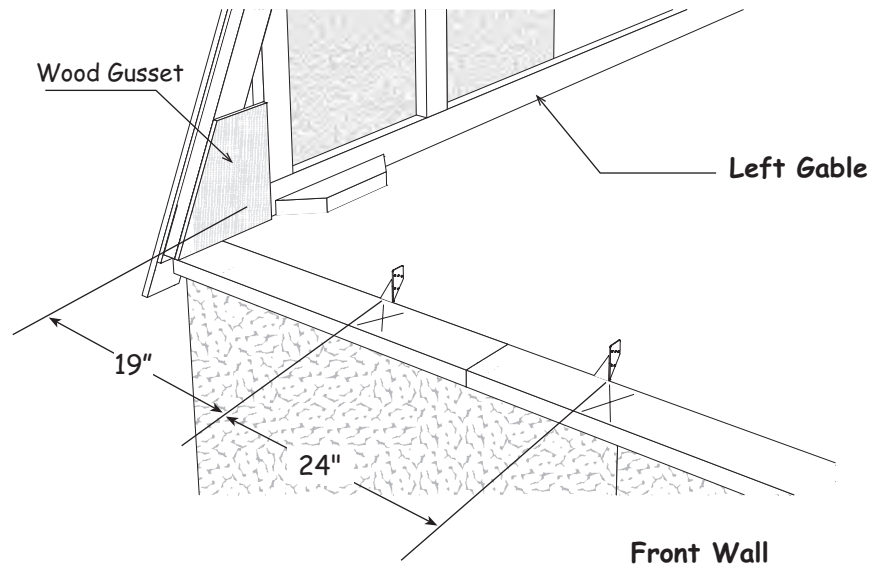

 Note: The center truss will not have a bottom cord.

Step 17 Install Loft Floor

1. Install a 4' x 4' OSB flooring panel between the siding on the left gable and the center of the 2nd truss. Notch the panel around the studs on the gable and cut the width to fit on the center of the 2x4 truss bottom cord. Secure floor with 6d common nails spaced 12" apart.
2. Cut and install 2' x 4' OSB panels on each side of the center panel.

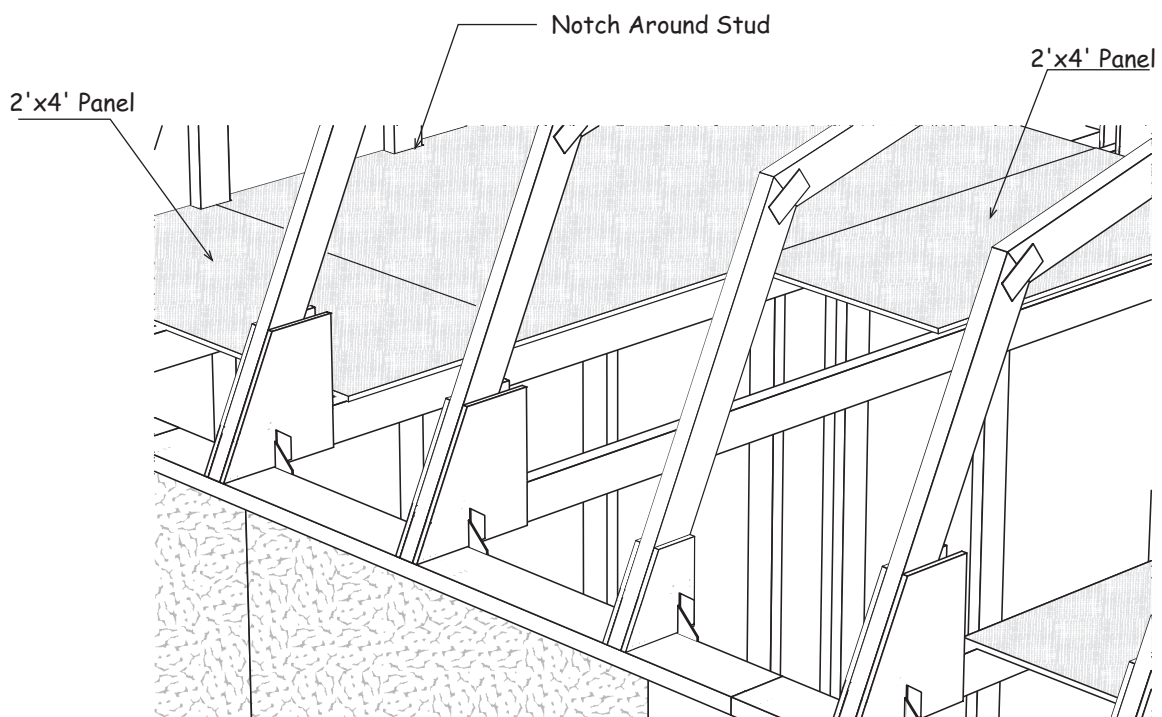

3. Install (2) two 2'x4' pieces as the 2nd row of flooring.
4. Install OSB flooring at the right side of the building.

Step 18 Install Roof Sheathing

Install roof sheathing on the steep side of the roof. Use a straight edge to align the top of the sheathing with the top of the truss. See Detail 'B'. Make sure the trusses are plumb and the roof sheathing meets the center of the truss. Use 6d common nails spaced 8" apart.

The top roof sheathing will not extend to the ridge. This will allow an opening for air ventilation should you install a ridge vent.

1. Working from left gable install a 42" x 72" OSB sheet against back of trim. Install 42" x 48" sheet next.
2. Install a 42" x 80" and cut to fit flush with face of 2x3 board on right side gable.
3. Install upper sheathing next cutting 80" to be flush with face of 2x3.
4. Install 1x4 gable trim.

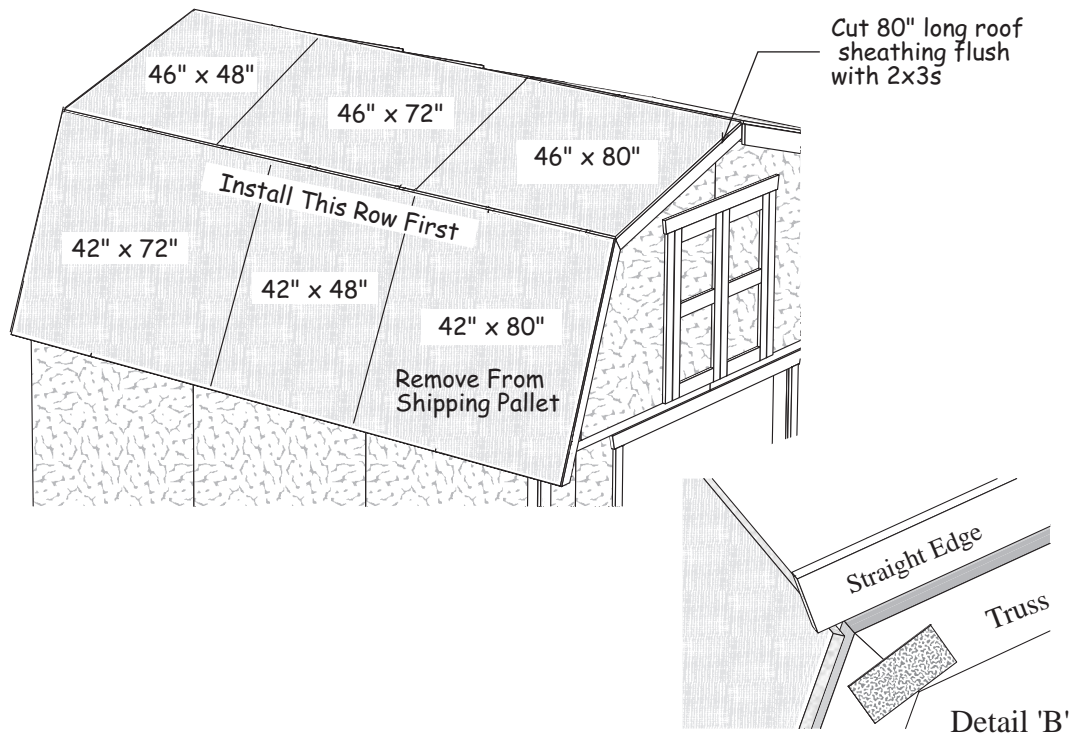

Install Shingles - not included in kit

Install roof shingles per instructions on outside of wrapper.

| | |
|------------------|---------|
| Roof Shingles | 10 bdl. |
| Roof 'drip' Edge | 7 pcs. |

Building Tip: Install ridge vent in lieu of shingles caps. Ridge vent provides ideal ventilation, preventing heat or moisture from damaging your building or its contents.

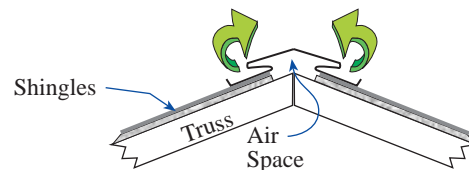

Step 19 Install Doors & Hardware

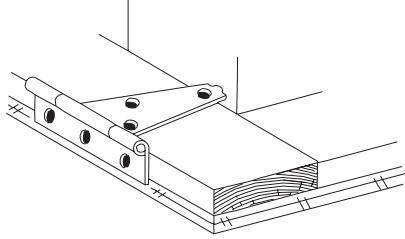

1. Lay the left door with the trim facing up. The siding on the left door extends past the door trim. See detail below.
2. Install 5" hinges to the left side of the door frame. To position the hinge properly, hold the rectangular plate against the frame. Use 1-1/4" black screws.
3. Install hinges to the right side of the other door.

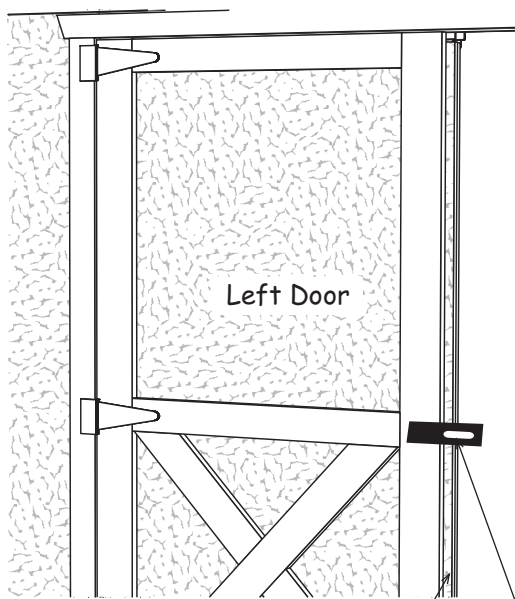

4. Before fastening the hinges to the side trim, temporarily prop the doors in the opening. Leave a space at the top and bottom of the doors and between the doors and the side trim to allow room for the doors to expand due to humidity.

If your door opening is out of square, the space around the doors will not be even. You can remove and re-position the side trim to make allowances for this. The side trim does not have to be flush with the frame of the door opening. You can move the trim in or out to make the door spacing equal.

5. Determine position of hinges and install to side trim with 2" screws.
6. Install door hasp on double doors. When properly installed the hasp will fold in half to receive locking latch and the screw heads will be covered.

Siding Extends Past Trim

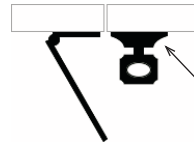

Fold Hasp to Cover Screws

Barrel Bolt on the back of left door

7. Install a barrel bolt on the lower back of the door to secure this door in place when closed. You will need to drill a hole for the round shaft to drop into.
8. Install another barrel bolt at the top of the door.

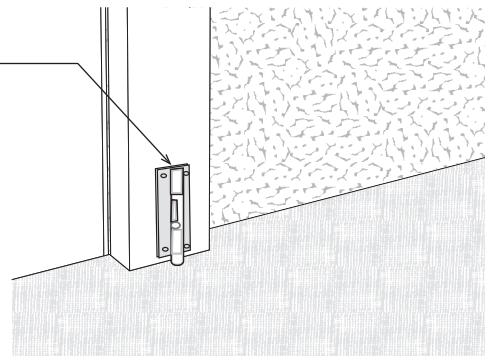

Meadowbrook and Woodville 10'x 16' Barn kit

| Qty. | <i>2x4 & 2x6 Framing</i> | Size | Qty. | <i>Trim</i> | Size |
|------|--|-------------|-------------------------------------|--|-------------------|
| 4 | Wall Plates | 120 " | 4 | 1x4 Gable Trim | 47 1/2" |
| 8 | Truss - Bottom Cords | 116 1/4" | 4 | 1x4 Gable Trim | 43 " |
| 37 | Wall Studs black ends | 72 " | 4 | 1x4 Corner Trim | 75 3/4" |
| 4 | Wall Plates | 68 1/2" | 4 | 1x4 Corner Trim | 74 3/4" |
| 4 | Wall Plates | 65 1/2" | 2 | 1x4 Door Trim | 72 " |
| 4 | Wall Plates | 56 1/2" | 1 | 1x3 Top Door Trim | 72 " |
| 2 | Wall Plates | 48 " | 4 | 1x3 Lower Wall Trim | 62 " |
| 4 | Gable Framing | 47 " | 2 | 1x3 Loft Door Trim | 29 " |
| 4 | Gable Framing | 38 " | 1 | 1x3 Loft Door Trim | 42 3/4" |
| 1 | Gable Studs & Framing | 36 " | Exterior Siding & Soffit | | |
| 1 | Gable Studs & Framing | 42 | 3 | 48" x 77-1/4" | 2 12" x 77-1/4" |
| 4 | Gable Studs & Framing | 34 1/4" | 2 | 36" x 77-1/4" | 6 48" x 75-3/4" |
| 4 | Gable Studs & Framing | 21 1/2" | 2 | 16" x 77-1/4" | 2 6" x 32-1/4" |
| 6 | Gable Nailing Blocks | 15 3/4" | 4 | Siding for Roof Gables | 48" x 48" |
| 2 | 2x6 Tie Plates for Side Walls | 48 " | 4 | Siding for Roof Gables | 16" x 30" |
| 4 | 2x6 Tie Plates for Side Walls | 70 1/2" | 1 | Siding For Header 6" x 32-3/4" & 6" x 32-1/4" | |
| | | | 4 | 8" x 48" Front Soffit Panels (Woodville model) | |
| | 2x3 Framing | | Hardware | | |
| 4 | Gable Overhangs | 47 " | 3 | lb. 10d Sinkers | |
| 4 | Gable Overhangs | 42 1/4" | 4 | lb. 6d Galv. | 28 Truss Hangers |
| 2 | Gable Blocks | 6 1/4" | 6 | lb. 6d Common | 75 Hinge Screws |
| | Pre-built Components | | 2 | lb. Hanger Nails | 1 Door Hasp |
| 14 | Pre-built Truss Halves | | | | 2 4" Barrel Bolts |
| 2 | 32" x 72" Pre-built Barn Doors | | | | 2 6" Barrel Bolts |
| 2 | 18" x 29" Loft Door Frames | | 4 | 4" Door Hinges | 12 2-1/2" Screws |
| 1 | 2x3 Door Header | 67-1/2" | 6 | 5" Door Hinges | 36 1-1/4" Screws |
| | Loft Floor & Roof Sheathing | | 26 | 1x4 Drive-on Plate | 24 1-5/8" Screws |
| 2 | 42" x 80" | 2 42" x 72" | Miscellaneous Lumber | | |
| 2 | 46" x 80" | 2 46" x 72" | 16 | Wood Truss Ridge Gussets | 8" x 24" |
| 2 | 48" x 48" | 8 24" x 48" | 28 | Wood Bottom Truss Gussets | 12" x 12" |
| 2 | 42" x 48" | 2 46" x 48" | 2 | Center Truss Blocks w/gusset | 3-1/2"x7-1/2" |