



Assembly Book

Revised August 21, 2024



the Weston

Building Size 12'x24'

Manufactured by RBS Holdings, LLC

205 Arlington Drive

Greenville, PA 16125

This manual is copyrighted. Under the copyright laws, this manual may not be copied, in whole or in part, without consent from

RBS Holdings, LLC

© Copyright 2022

IMPORTANT INFORMATION ABOUT YOUR KIT

Thank you for purchasing our kit. Please read the following information before beginning construction. Always check with your local HOA or building code office for any requirements or restrictions.

Floor: Wood flooring is sold optionally. You may choose to build your own or pour a cement pad.

Always wear safety glasses when cutting or nailing!

Tools Required:	Hand or Circular Saw	Level	Safety Glasses
	Cordless Drill	Measuring Tape	Dust Mask
	Hammer	6'-8' Ladder(s)	Phillips Screwdriver
	Pencil		Framing Square

Additional Materials - **Not included in kit:**

Required: Shingles or metal roofing, Drip Edge, Roofing Nails or Screws, Paint
Exterior wall covering such as vinyl siding, lap siding or stucco.

Optional: Caulk, Ridge Vent

Terminology:

Square - Confirm corners are at 90 degrees
Plumb - Confirm walls and trusses are straight vertically
Wall Plate - Top and bottom 2x4s used to frame walls
Tie Plate - 2x4s connecting wall sections together
Header - Spans top of door opening
OSB - Oriented Strand Board

Organize:

Unpack all items & organize according to size and type. This will make items easier to find when instructed.

Review the parts list on the back page. Should there be missing items or sub-par material contact Best Barns Customer Service.

DO NOT discard any material including the pallet until your project is complete.

Assembly:

Review all instructions before you begin. Please follow steps carefully and in sequence for successful results.

If you have any questions we are happy to assist you. Please contact us at:

800-245-1577 - Mon - Fri 8AM - 5PM EST

724-866-4357 - After hours and weekends

Email - questions@barnkits.com

Details for Optional Sturdy-Built Floor System

Foundation size is 12'-0" x 24'-0". Check local building codes in your area, the construction may have to change. For a concrete slab, install sill sealer as a moisture barrier between the concrete and the wall plates. Foam sill sealer can be purchased at home centers in rolls 3-1/2" or wider.

1. Cut (2) two 2x4-12' to a length of 12' -0". They will be used for the joist headers. Layout, from the left, for 12" on center joist spacing. The 'X' marks where floor joist will be placed.

←11-1/4"→	←12"→	←12"→		
X	X	X	X	X
X	X	X	X	X
2. Cut (13) thirteen 2x4-12' floor joist to 11'-9". *Treated lumber may be thicker than 1-1/2"*. Take this into account when cutting the length of floor joists. Shorten the joist measurements if necessary to obtain 12'-0" building width.
3. Place 4x4-12' treated timbers on the ground. Cut (2) two 2x4-8' boards into 2' long blocks to secure the 4x4s where they butt together.
4. Install the floor joists cut above between the 12' joist headers. Secure with 16d galv. deck nails.
5. Place floor sections over the 4x4s. Square floor. Measure the floor diagonally (corner to corner). These measurements will be the same if the floor is square. To keep the 2x4 frame from moving, toenail frame to the 4x4 runners.

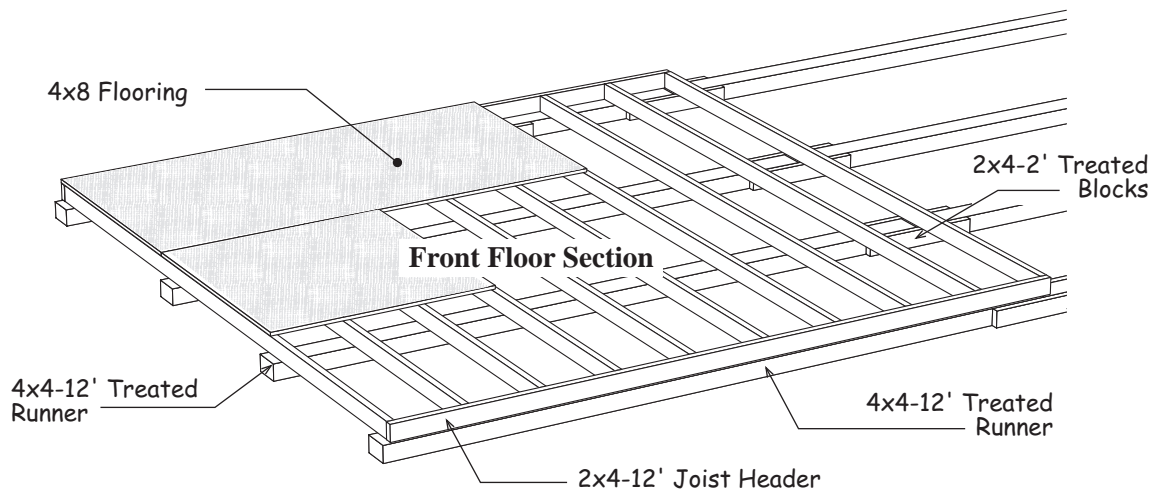

Assembly Instructions for Rear Floor Section

6. Repeat step number 1 and 2 above and assemble another floor section.
7. Install this section against the front floor section. Nail together with 16d galv. deck nails.
8. Install 4x8 flooring over the 2x4s. Use 8d galv. spiral nails.

Material Description	12' x 24'
2x4 Blocks	2 pcs. 8'
2x4 Joist Headers	4 pcs. 12'
2x4 Floor Joist	26 pcs. 12'
4x4 Treated Runners	8 pcs. 12'
Flooring 3/4"	9 pcs. 4x8
Screw Floor Nails	5 lb. 8d
Galv. Box Nails	5 lb. 16d

Step 1 Assemble Side Walls

 **Do not discard any material until construction is complete, including short 2x4 blocks.**

1. Cut (2) two 2x4-12' to a length of 140-1/2". Position the boards together and indicate with 'X' marks where the wall studs will be located.

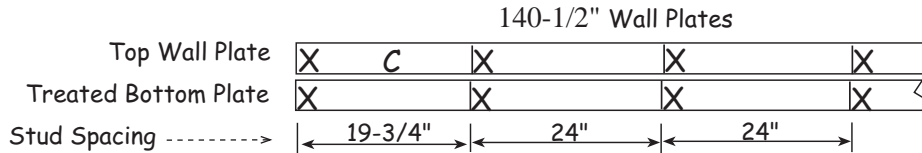

2. Mark a 'C' anywhere between first two studs. This is referenced in a later step.
3. Install (7) seven pre-cut wall studs between the top & bottom plates. Nail top plate to studs using (2) two 10d sinkers per stud. Nail bottom plate to studs using (2) two 16d galv. nails per stud.

 *The length of pre-cut studs will vary from 92-1/4" to 93" depending on your locality.*

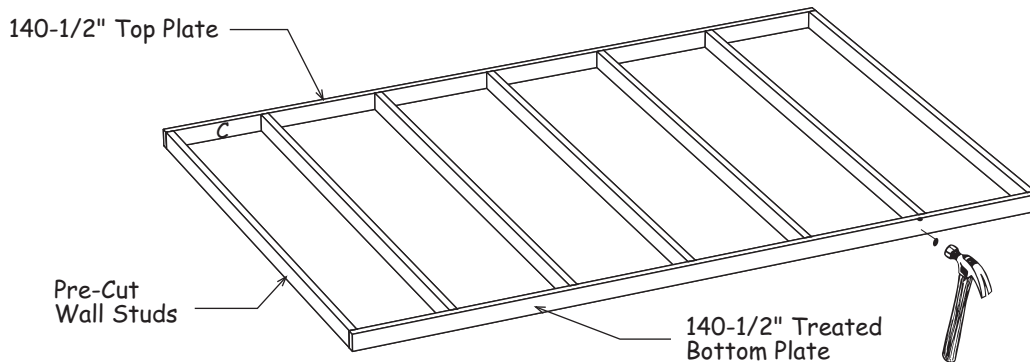

4. Repeat to assemble (3) three more 140-1/2" long wall frames.
5. Set frames aside.

Step 2 Assemble Door Header

1. Locate (2) two 2x8-10' boards. Cut these boards to a length of 99".
2. Assemble the door header using 2x8 boards and (2) two 7-1/4" x 48" OSB fillers. Position OSB fillers 1-1/2" from either end of 2x8s. Nail together with (12) twelve 10d sinkers spaced evenly on each side.

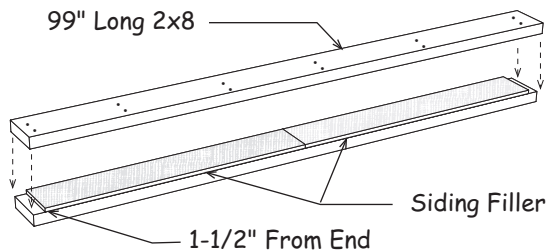

Step 3 Assemble 12' Back Wall

1. Cut (2) two 2x4-12' (one will be treated) to a length of 144". Position the boards together and indicate with 'X' marks where the wall studs will be located.

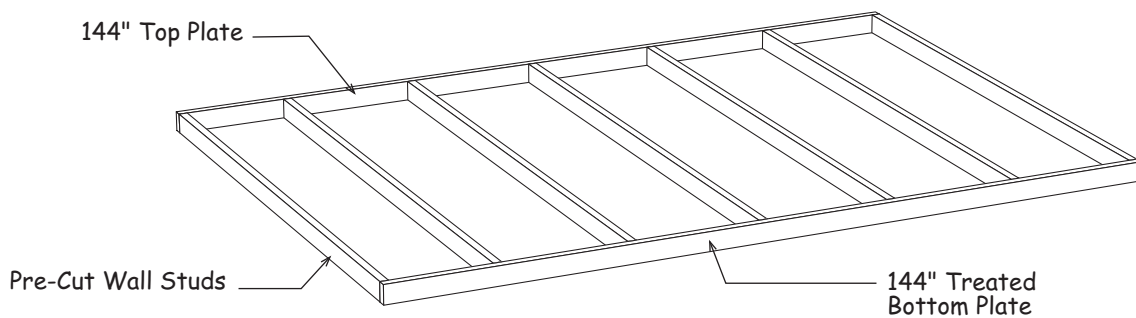
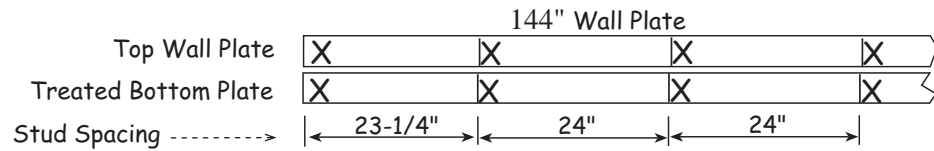

2. Install (7) seven pre-cut wall studs between the top & bottom plates. Nail top plate to studs using 10d sinkers. Nail bottom plate to studs using 16d galv. nails.
3. Square wall frame. Measure the wall diagonally (corner to corner). Then measure the opposite corners. These measurements will be the same if the wall is square.
4. Install the first OSB panel flush with the side of the wall stud and flush with the top 2x4 plate. Nail siding with 6d common nails, spaced 8" apart. Cut the OSB flush with the 2x4 bottom plate if you are installing the building on a concrete slab.
5. Install (2) two more OSB panels.

 Depending on length of pre-cut studs siding may extend below bottom plate.

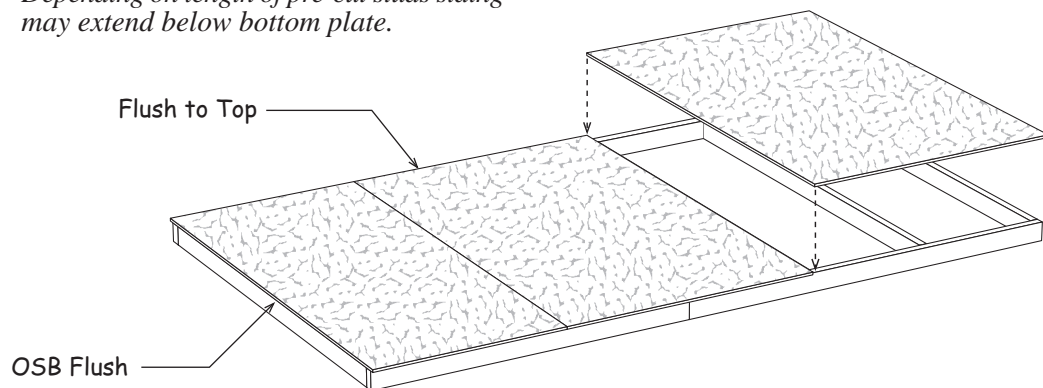

Step 4 Assemble Front Wall Frame

1. Cut (2) two 2x4-12' boards (one will be treated) to a length of 144" for wall plates. Position the boards together and indicate with 'X' Marks where the wall studs will be located. Mark an 'S' on the bottom plate where the door header supports will be located.

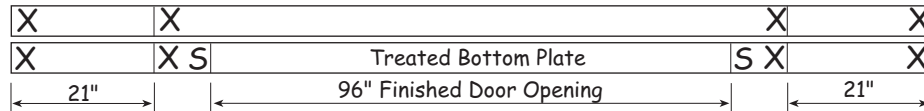

2. Install (4) four pre-cut wall studs between the wall plates where shown. Nail top plate to studs using 10d sinkers. Nail bottom plate to studs using 16d galv. nails.

3. Cut (2) two pre-cut wall studs to a length of 82" and install as header supports over 'S' marks. Nail to studs using 10d sinkers.

4. Install the door header on the header supports. Nail to the wall stud with 10d sinkers.

5. From a pre-cut stud cut (5) five blocks to fit between top plate and header. Nail through top plate and toenail to header using 10d sinkers.

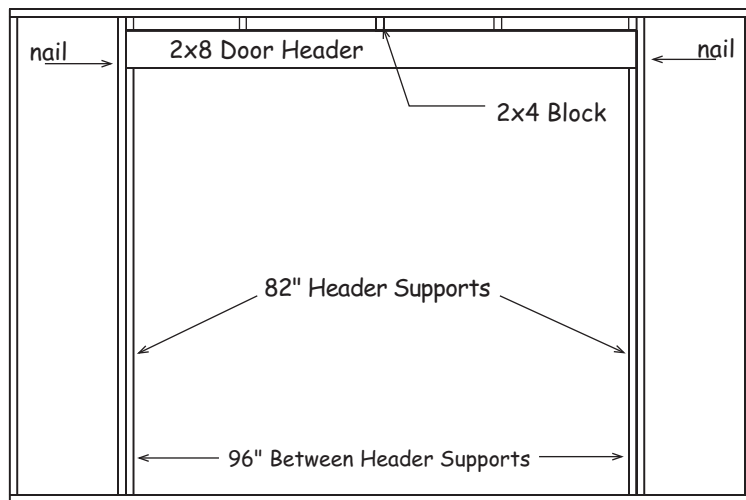

6. Cut a 4x8 OSB panel in half creating (2) two 2'x8' panels. Install one panel flush with the side of the door opening and flush with the 2x4 top plate. Use 6d common nails.
7. Locate (2) two 20"x 48" OSB panels and install above the door opening. Cut these to fit above door opening with bottom edge 3/4" below door header.
8. Install 2'x8' OSB panel on the right side of the wall panel.

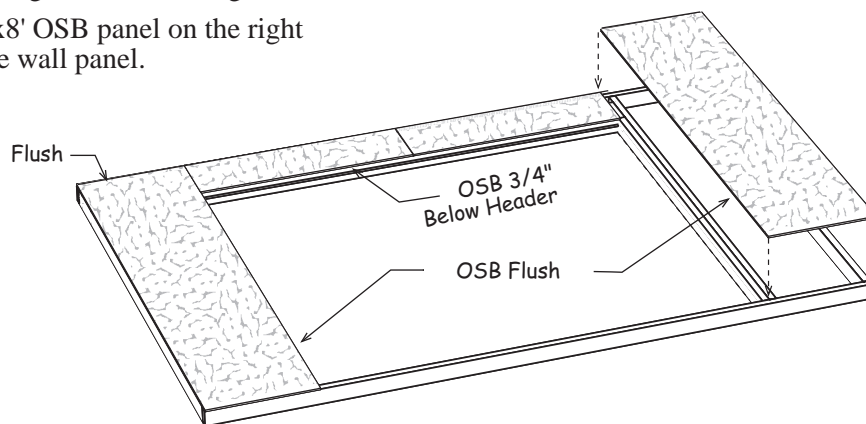

Step 5 Set Wall Panels

1. Erect back wall and side walls. The 'C' marks on side walls must be at each end. Secure walls together at the corners. Use (4) four 10d sinkers per corner. Brace side walls with pre-cut wall studs to hold walls secure and plumb.
2. Cut a OSB panel in half lengthways. Install a 24" wide panel at the back corner, flush with the back wall 2x4 frame and flush with top plate. Nail OSB to back wall and all 2x4s using 6d common nails spaced 8" apart
3. Install (5) five more OSB panels. The last 24" wide panel will extend 3-1/2" past wall to receive front wall panel.
4. Start at back wall and OSB siding to opposite wall.
5. Erect front wall panel and secure corners with 10d sinkers. Nail OSB to front wall.
6. Cut and remove bottom 2x4 from door opening.
7. Nail frames to the floor using 16d Galv. spiral nails or, if erecting on a cement slab, concrete anchor bolts (*not included*) spaced 24" on center.

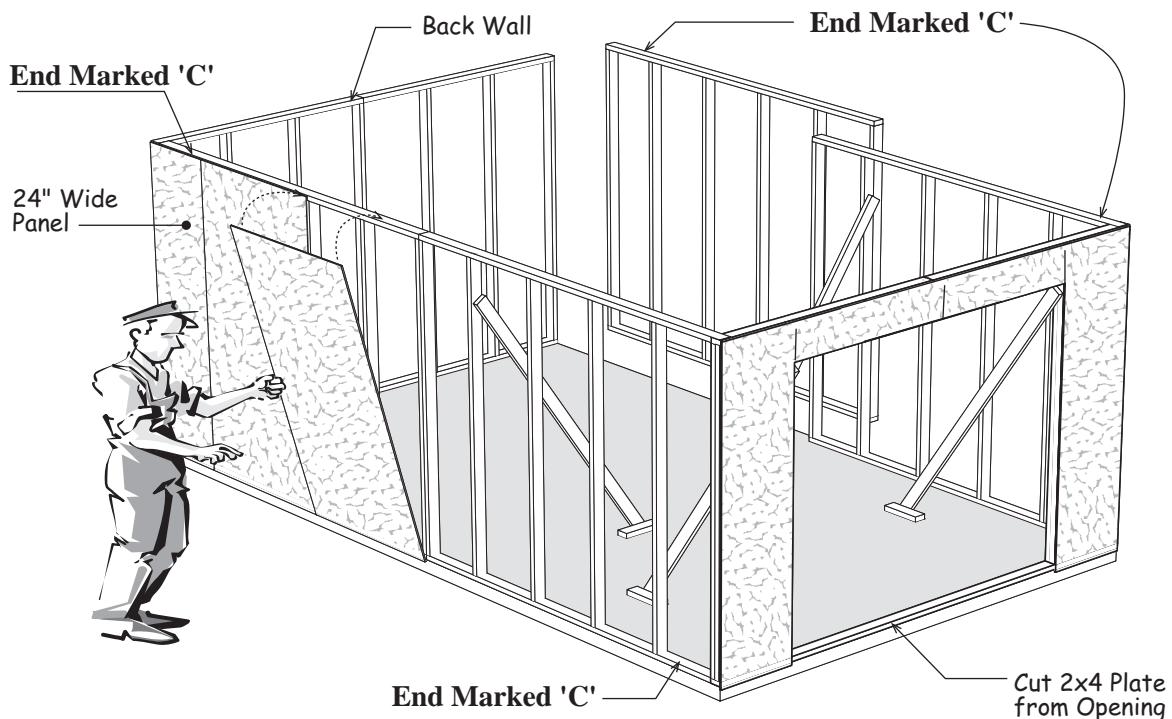

Step 6 Assemble Roof Gables

1. Cut (2) two 2x4-12' boards to a length of 144".
2. Place one of the 144" boards on the floor along with (2) two 80-1/2" long 2x4 rafters as shown below. Bottom 144" plate will be on edge. Rafters will lay flat.



There are short 2x4s, *that may have an angle on one end*, supplied in the kit. Use these to hold the rafters and bottom gable plate together by temporarily screwing the blocks to the floor using 2-1/2" screws. This will ensure that the gable frames and the trusses are identical.

3. Secure the top of the rafters together with a 1"x4" barbed metal drive-on plate.
4. Install (2) two 23-1/2" gable studs with angle cut at one end. Nail through the bottom plate with 10d sinkers and secure the top with barbed metal drive-on plates.

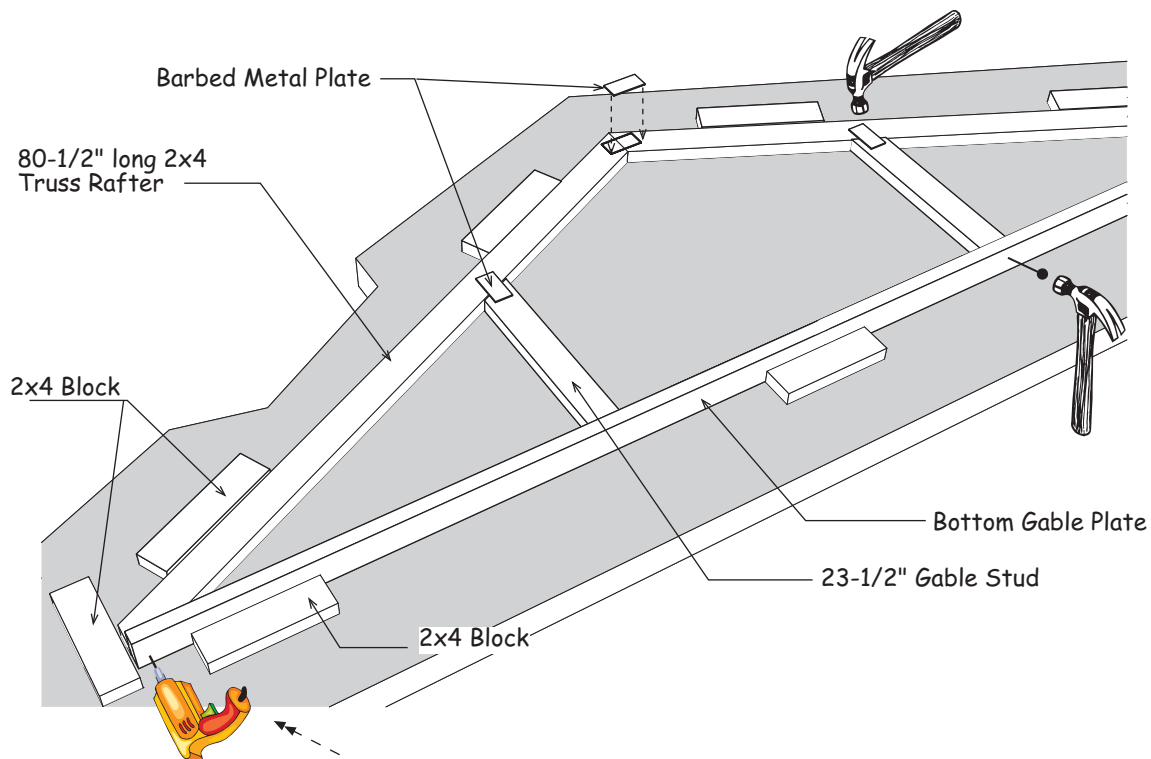

6. Secure the 2x4 bottom plate to the truss rafter with a 2-1/2" wood screw on both ends. Set gable aside.
7. Repeat steps to assemble another gable.

Step 7 Assemble Roof Trusses

1. Place (2) two 80-1/2" long 2x4 truss rafters and a 82" long collar tie together as shown below. The collar tie has an angle cut on both ends. Reposition the lower 2x4 blocks to hold the truss rafters in place. See **'Detail B'**.
2. Secure the 2x4 truss rafters at the top with a 8" x 16" wood gusset. Nail the gusset to the 2x4s with (14) fourteen 6d common nails,
3. Secure the 2x4 collar tie with (4) four 2-1/2" long wood screws at each end. Tip: Pre-drill holes with an 1/8" bit to prevent wood splitting at ends.
4. Turn this truss over and apply a wood gusset to the opposite side at the ridge.
5. Repeat to assemble (10) ten more trusses.

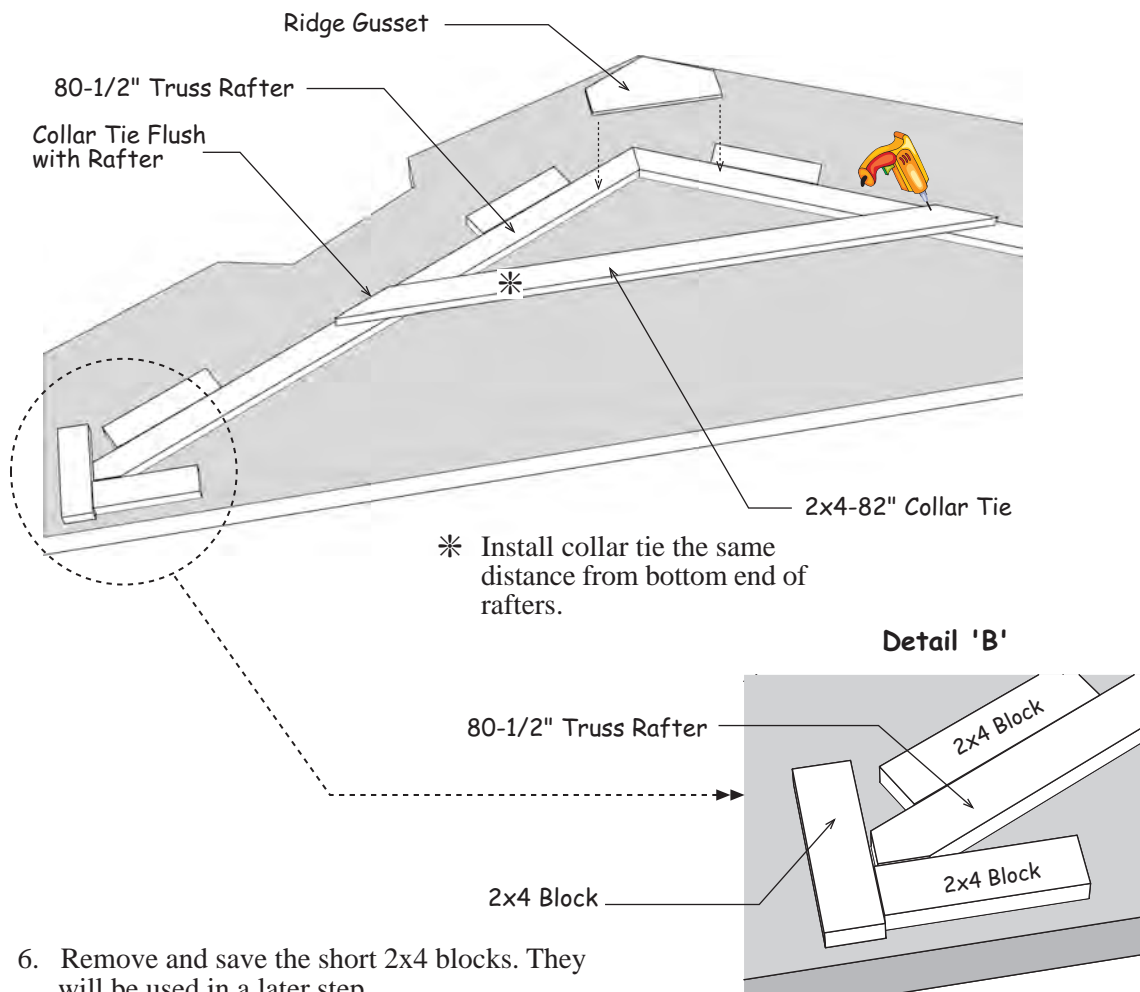

Step 8 Install Primed Soffit and Fillers

1. Install a 7" wide x 48-3/4" siding panel over the side wall with the primed side facing down. The 'tongue' edge should be flush with front wall plate, NOT over OSB. Tack the soffit with a couple 6d common nails. Installing 2x4 tie plates in a later step will provide more nailing.
2. Install (5) five more siding panels. Cut the last soffit flush with the 2x4 wall plate.

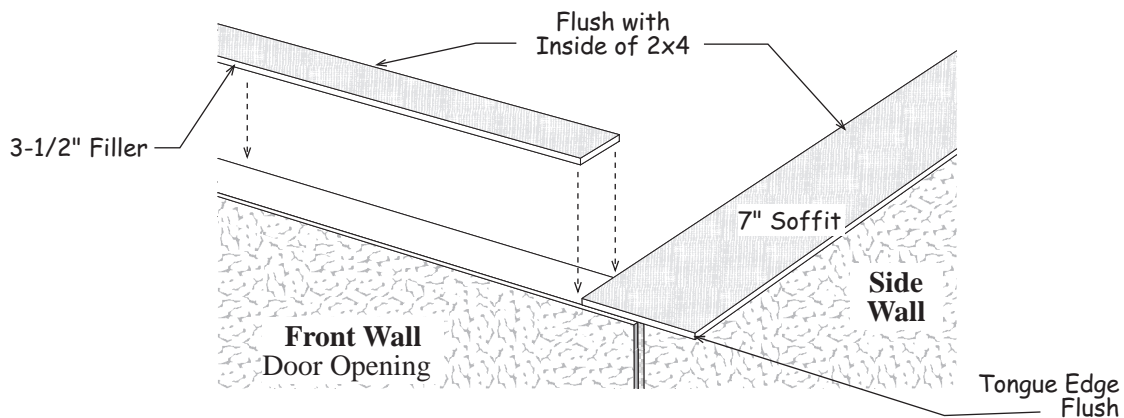

4. Repeat to install soffit on the opposite side wall.
5. Install (3) three 3-1/2" wide x 48-3/4" filler panels over the front and back wall. Cut the last filler to fit between the soffit on the side walls.

Step 9 Install Roof Gables

1. Install a gable frame centered on the back wall. Gable plate should be flush with filler. NOT over OSB. Secure with 10d sinkers spaced 16' apart.
2. Install the gable frame on the front wall.

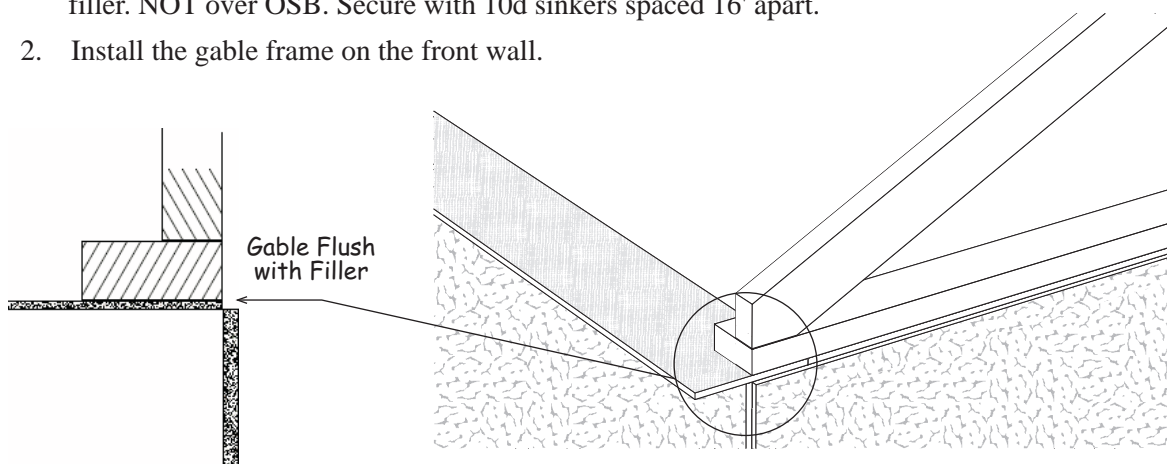

Step 10 Install Siding on Gables

1. Locate pre-cut gable OSB. Install OSB above the lower OSB wall panels and flush with ends of gable frame. Make sure OSB doesn't extend above top of frame. Use 6d common nails.
2. Repeat to install OSB on the other gable frame.

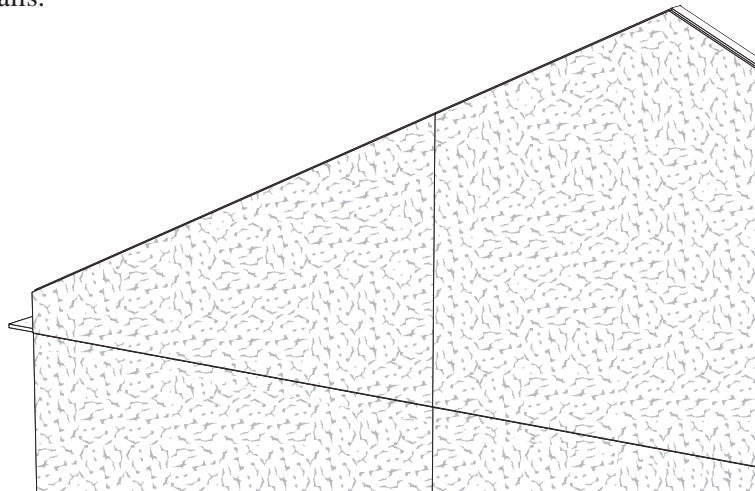

Step 11 Install 2x4 Tie Plates on Side Walls

1. Install a 2x4-12' on a side wall against the gable on the back wall and flush with inside of soffit. Cut a 2x4x-12' to fit against gable on front wall. Use 10d sinkers spaced 16" apart.
2. Repeat to install tie plates on the opposite side wall.

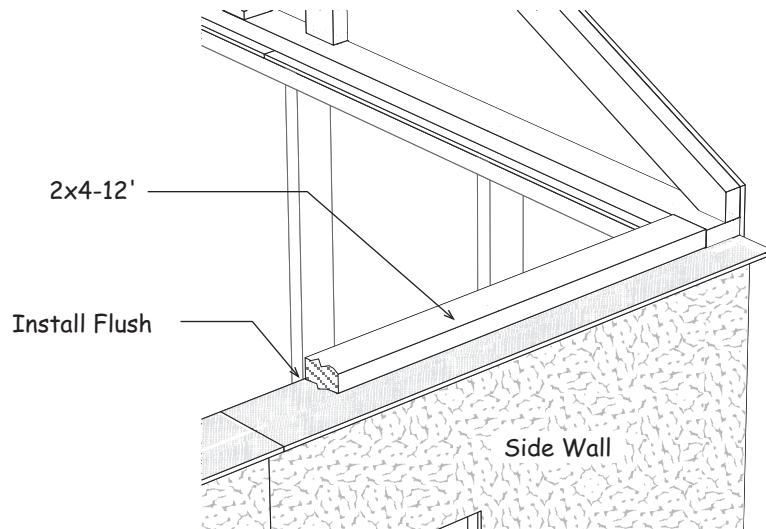

Step 12 Layout Roof Trusses & Install Soffit Blocks

1. Starting on back corner measure from the backside of the 2x4 gable frame when marking the location of the first truss. Continue 24" spacing to other gable. **Important:** When marking the opposite wall, place the 'X' mark on the same side of the line so your trusses are parallel when they are installed.
2. Install metal hangers to the tie plate with 1-1/2" hanger nails . The opening should line up with the 'X' mark, the bottom of the opening, flush with the 2x4 tie plate. **Detail 'D'**.

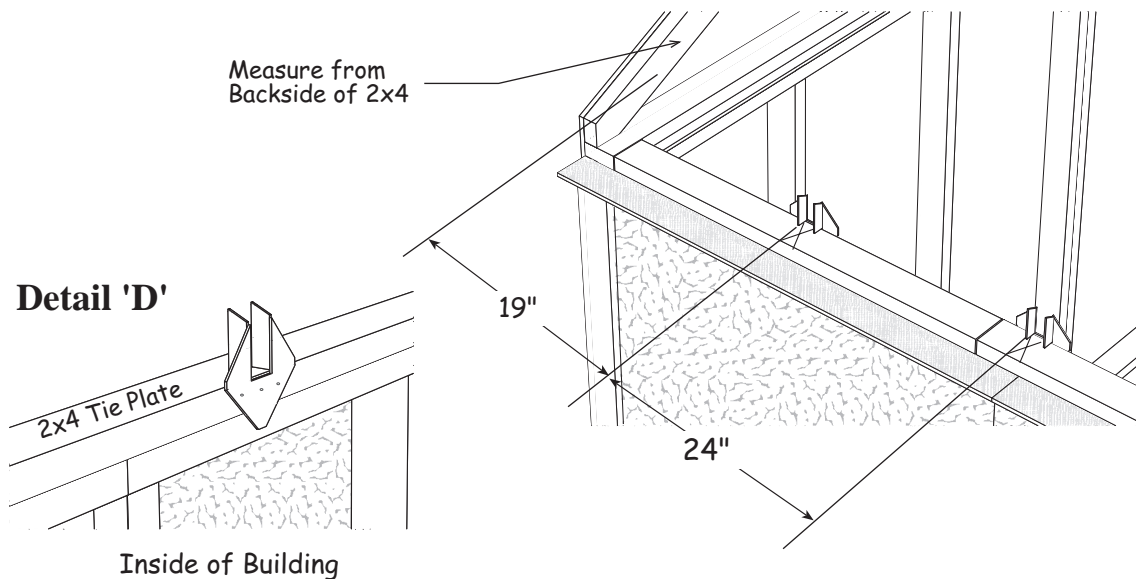

3. Set roof trusses. Secure trusses to metal hangers with 1-1/2" hanger nails.
4. Gather (22) twenty two short 2x4 blocks and install one at both ends of each truss. Secure 2x4 blocks to the soffit panel using (2) two 1-1/2" long exterior screws.
5. Gather (4) four more 2x4 blocks. Install one 2x4 block at each end of the soffit, flush with the 2x4 gable frame.

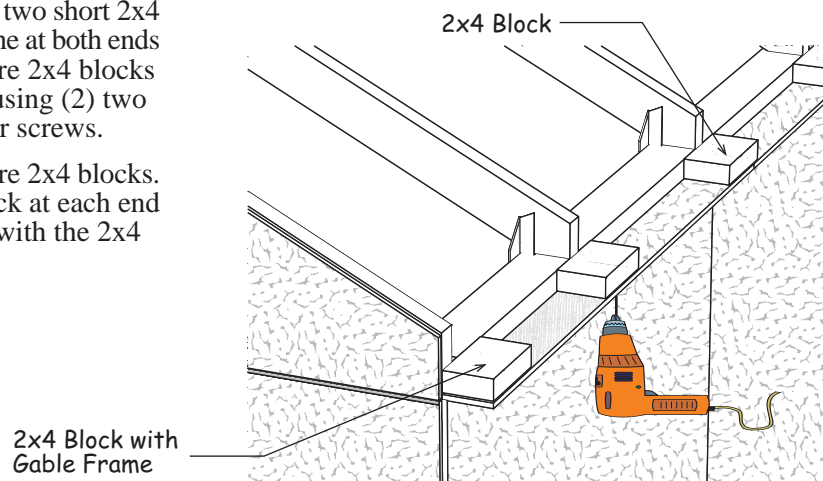

Step 13 Install Rear Gable Trim

 **The front able trim will be installed in a later step.**

- 1 Install (4) four small OSB fillers, *packed with the hardware*, over the 2x4 soffit blocks. Fillers will be flush with the gable siding. Use 6d common nails.

OSB Siding Filler

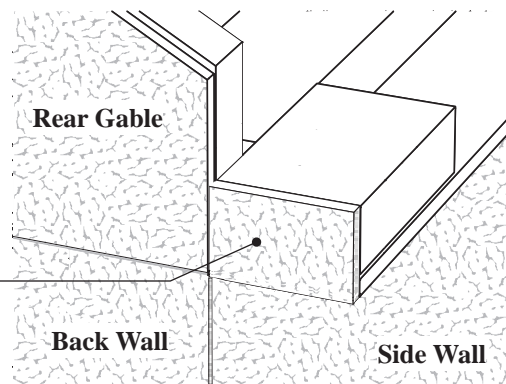

2. Install (4) four 42-3/8" long 2x3 boards on the rear gable flush with the top of the gable frame. Use 10d sinkers

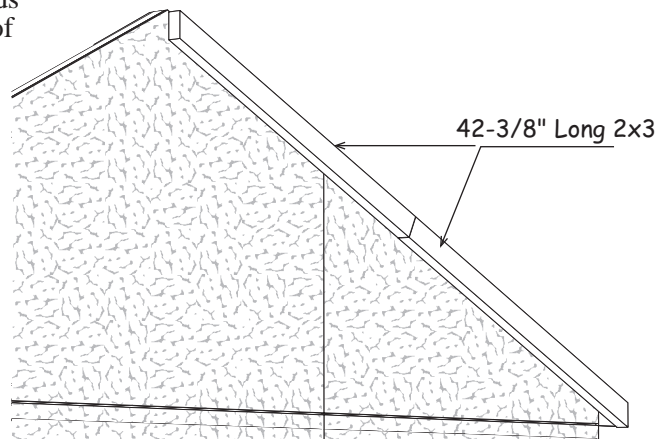

3. Install a 8-1/2" long trim board, called a keystone, at the top of the gable flush with the top of the gable frame. Use 6d galv. nails.

Keystone

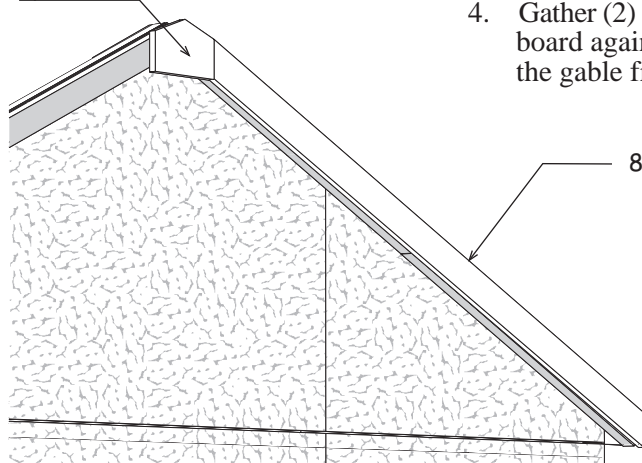

4. Gather (2) two 82-1/2" long 1x4 trim boards. Butt each board against the keystone and flush with the top of the gable frame. Use 6d galv. nails spaced 12" apart.

82-1/2" Long 1x4 Trim

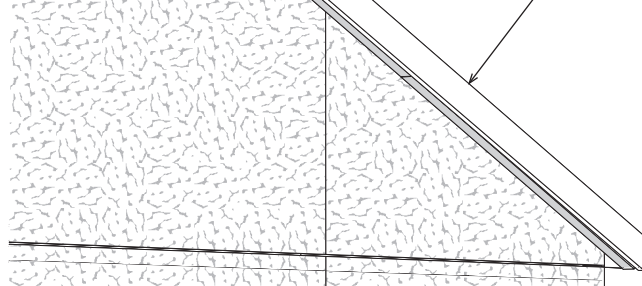

Step 14 Install Fascia on Side Walls

1. Install a 1x4-4' fascia trim board against the rear gable trim. Install the fascia so the bottom edge of the roof sheathing will rest on the edge of the 1x4. **See Detail 'E'**. Use a straight edge to align the 1x4 board with the top of the trusses. Use 6d galv. nails.
2. Install (3) three more 6' fascia boards. Do not install the last fascia board. This will be applied after the front overhang is installed.
3. Repeat on opposite side wall.

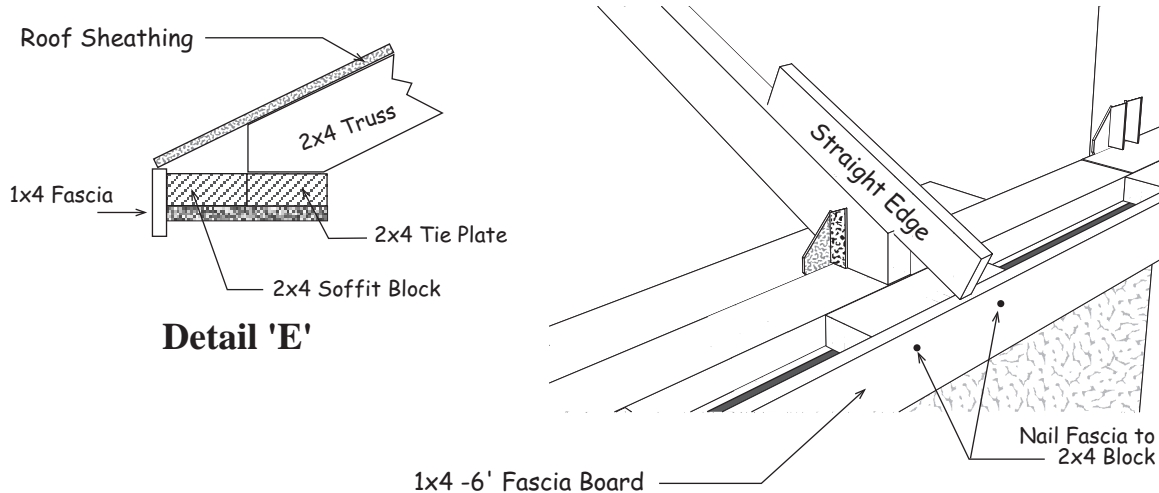

Step 15A Install Roof Sheathing

1. Install (4) four 42-3/8" long 2x3 boards on the front gable flush with the top of the gable frame. Use 10d sinkers
2. Plumb each truss and gables.
3. Refer to sheathing layout at the top of the next page. Install roof sheathing starting at the front gables lower corner. The roof sheathing should extend 6-1/4" beyond the 2x3s. Continue to back wall. Use 6d common spaced 8" apart. The top row of roof sheathing will be about 1" below the ridge to allow for optional ventilation.

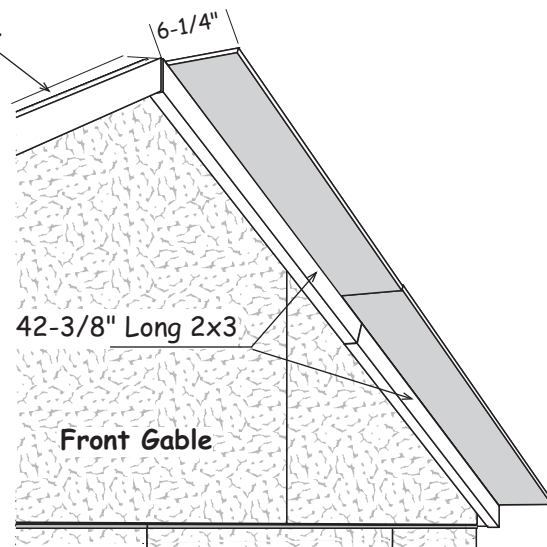
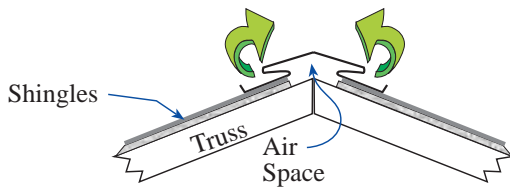

Step 15B Install Roof Sheathing continued

 Sheets should meet at center of trusses when installed

- From (2) two 4x8 sheets of OSB cut (2) two 48" x 48" and (2) two 36-1/2" x 48" pieces. Cut (2) two 4x8 sheets of OSB into 36-1/2" x 96". Install these sheets indicated with an * along with the pre-cut sheets as shown below.

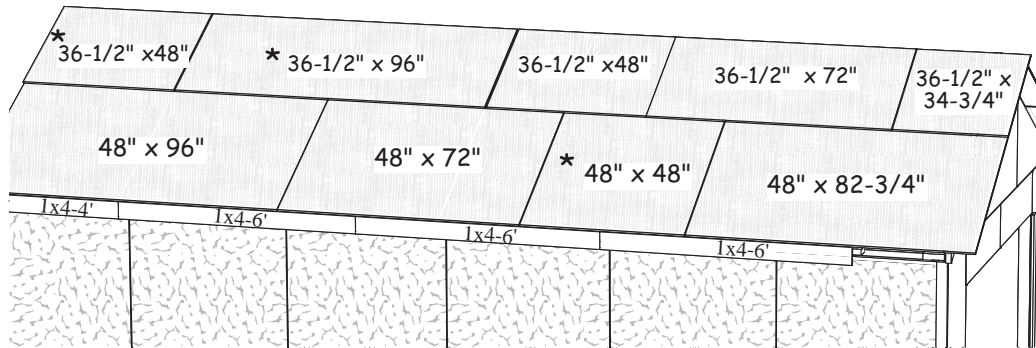

- Trim off any sheathing that extends over the rear gable trim.

Step 16 Install Front Soffit

- Gather (2) two 7" wide soffit panels. Install first panel, prime side down, flush with lower end of 2x3 and butted against siding. Install with 1-1/2" exterior screws. Cut upper panel to fit.
- Install (2) two 42-3/8" long 2x3s between the roof sheathing and the soffit panels. Use 1-1/2" exterior screws through soffit and 6d common nails through roof sheathing. Set these boards flush with soffit panels. The roof sheathing will extend 3/4" past the 2x3s to allow for trim.

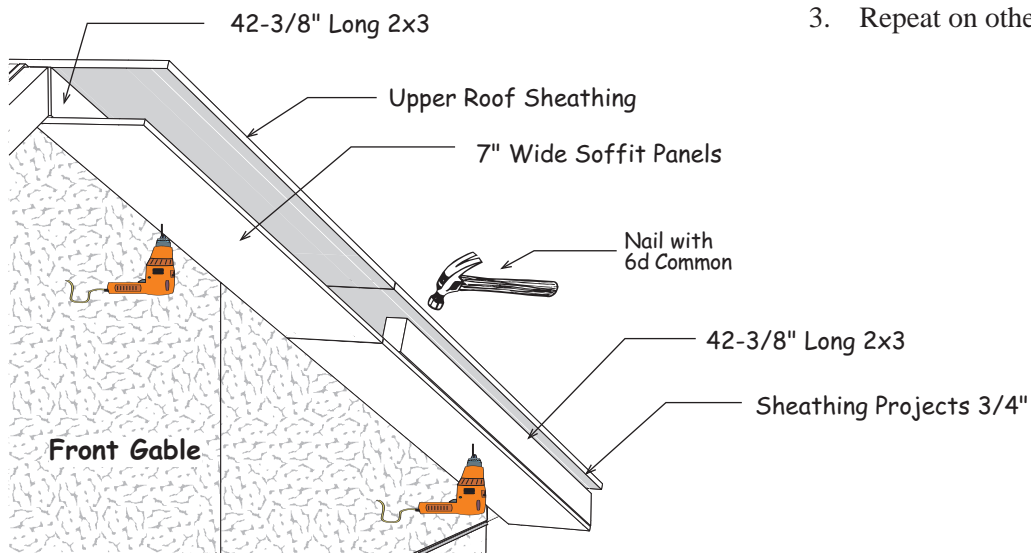

- Repeat on other side.

Step 17 Finish Side Wall Trim

1. Locate (2) two 1x4-6' trim boards. Cut each to fit against back of front gable trim and install on the side walls.

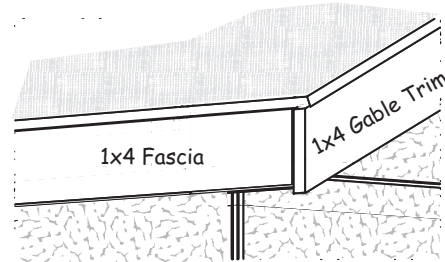

Step 18 Install Gable & Door Trim

1. Install a keystone and gable trim under the roof sheathing as done in **Step 13**.

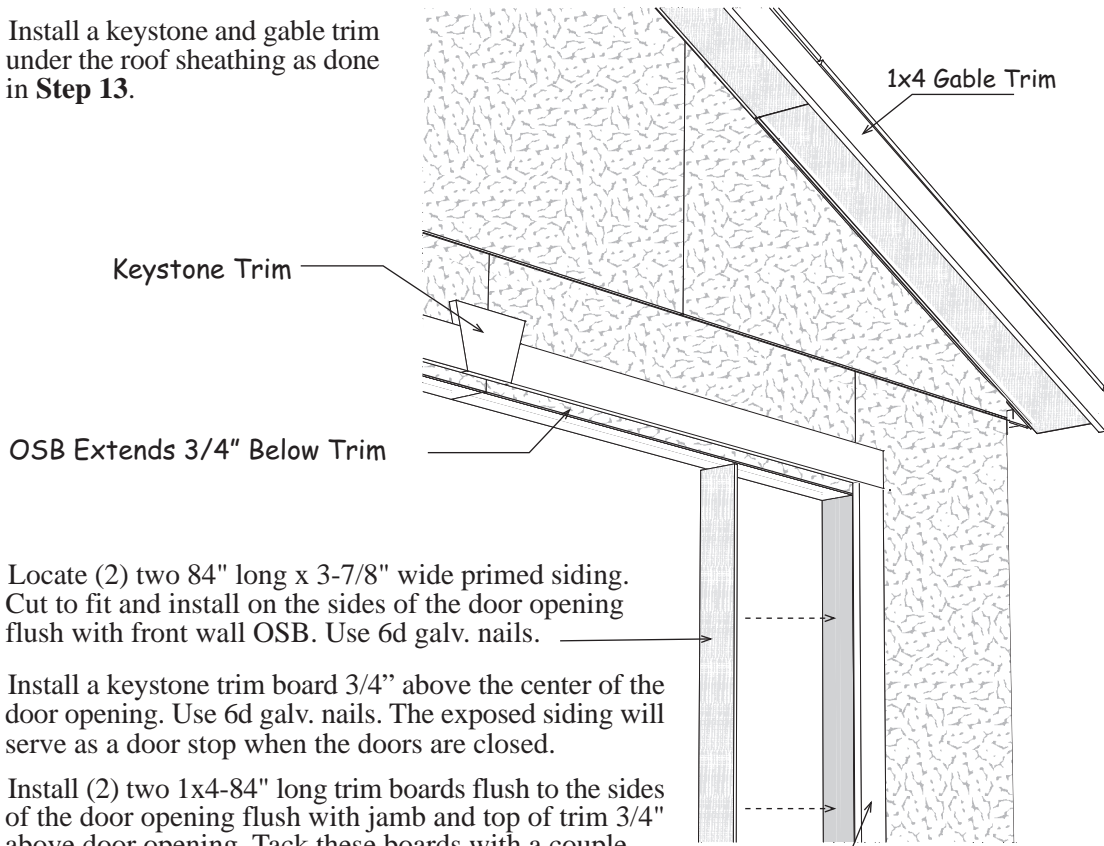

2. Locate (2) two 84" long x 3-7/8" wide primed siding. Cut to fit and install on the sides of the door opening flush with front wall OSB. Use 6d galv. nails.
3. Install a keystone trim board 3/4" above the center of the door opening. Use 6d galv. nails. The exposed siding will serve as a door stop when the doors are closed.
4. Install (2) two 1x4-84" long trim boards flush to the sides of the door opening flush with jamb and top of trim 3/4" above door opening. Tack these boards with a couple nails, you may want to reposition the trim when you install the doors.
5. Locate 1x4 trim boards with an angle cut on one end. Install these against the keystone. Cut boards so to be flush with outside of vertical trim.

Step 19 Install Roofing — Not Supplied in Kit

Roof Covering	
14 bdl.	Roof Shingles
10 pcs.	Roof 'drip' Edge-10'

Step 20 Install Door Stop on Left Door

Qty.	<i>Material Shipped in 48" Door Kit</i>	
2	ea.	48" x 84" Pre-built Doors
2	ea.	12" x 42" Transom Windows
2	ea.	1x4" x 84" Door Trim
2	ea.	1x4" x 48-3/4" Door Trim
1	ea.	1x6" x 10" Keystone
2	ea.	3-7/8" x 84" LP 3/8" Primed Door Jamb
6	ea.	6" Door Hinges
1	ea.	Door Handle & Latch
1	ea.	6" Barrel Bolt
52	ea.	2" Hinge Screws
16	ea.	3/4" Pan Head Screws
10	ea.	1-1/2" Exterior Screws
32	ea.	White Window Screws

Install a 4-1/4" x 83" long board as a door stop to the right side of one of the doors. This will be the left door when installed. The door stop should extend 3/4" beyond the frame of the door. Install with 1-1-2" exterior screws packed in the main component kit. Space screws 12" apart.

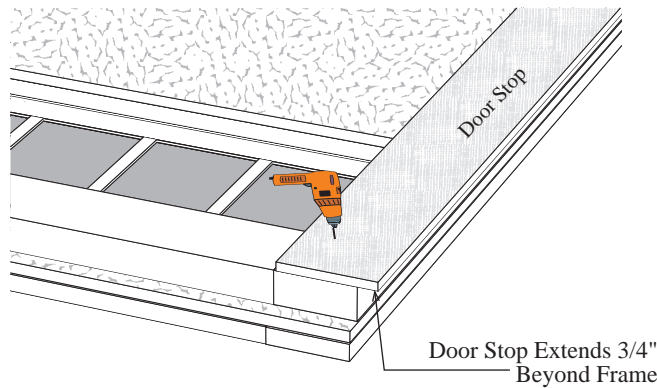

Step 21 Install Doors



If your door opening is out of square, the space around the doors will not be even. You can remove and re-position the side trim to make allowances for this. The side trim does not have to be flush with the frame of the door opening. You can move the trim in or out to make the door spacing equal.

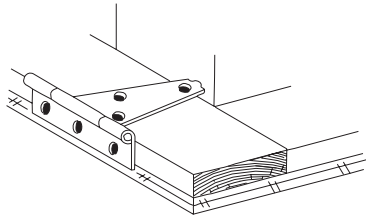

1. Install (3) three 6" hinges to sides of the doors. To position the hinge properly, hold the rectangular plate against the frame. Use 2" black screws.
2. Before fastening the hinges to the trim, temporarily prop the doors in the opening. Leave a space at the top and between the doors and the side trim to allow room for the doors to expand due to humidity.
3. Determine position of hinges and install to side trim with 2" screws.
4. Install the window using the short white screws.
5. Install door handle using 2" black screws into the pre-drilled hole on right side door. When the handle is turned the inside latch will hold doors closed. Tighten set screw to finish.

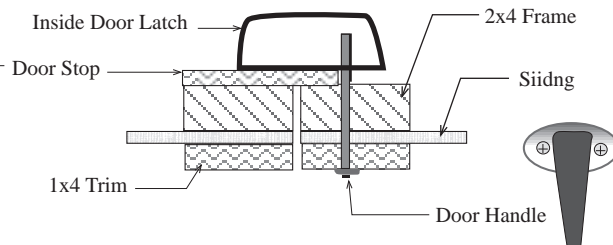
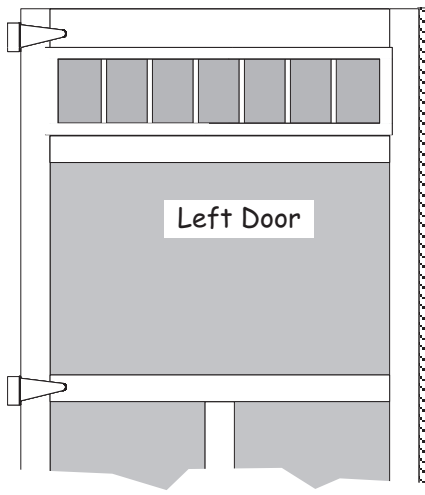

6. Install a barrel bolt using 3/4" pan head screws on the lower back of the door to secure this door in place when closed. You will need to drill a hole for the round shaft to drop into.
7. Install another barrel bolt at the top of the door.

Vinyl Siding General Information

Install the siding according to the manufacturer's instructions.

Material List for Vinyl Siding		
5-1/2 sq.	Vinyl Siding	<i>double 4" standard profile</i>
4 ea.	Outside Corners	
5 ea.	J-Channel	
5 ea.	Under Sill Trim	
6 ea.	Starter Strips	
3 lb.	Nails	

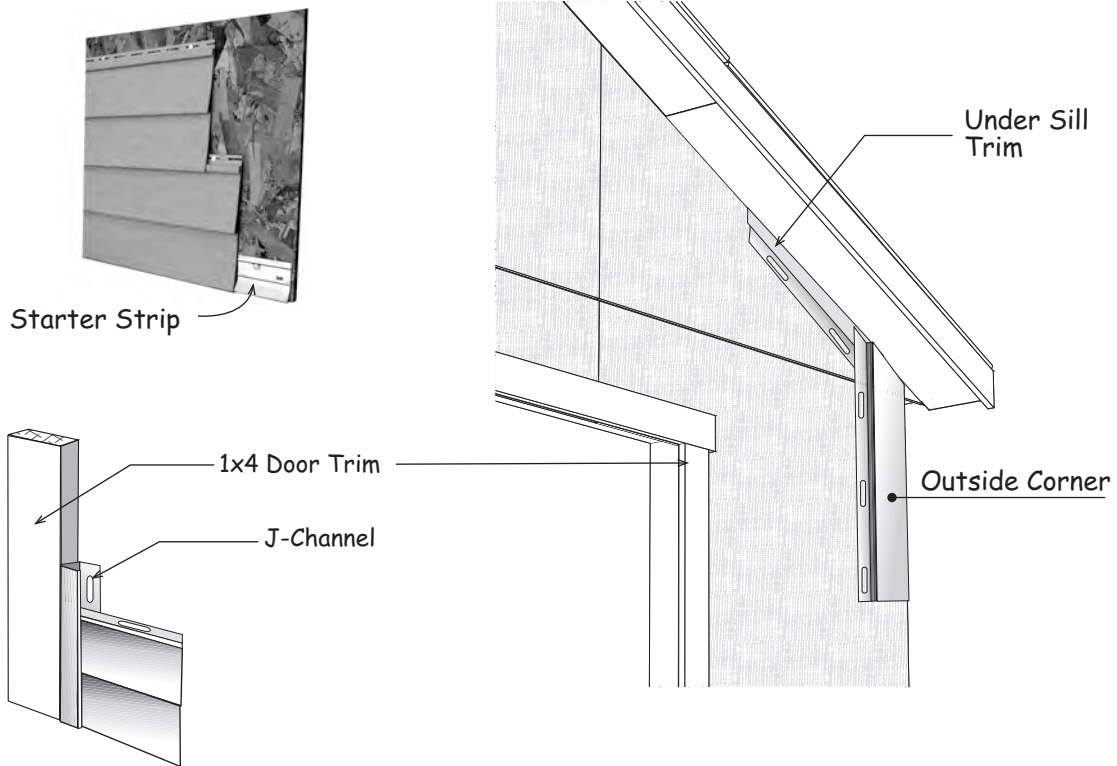

Weston 12x24 Material List

7	2x4 for Collar Ties	82"
18	2x4 for Truss Rafters	80-1/2"
4	2x4 for Gable Studs	23-1/2"
18	2x4 for Soffit Blocks	5" or longer
6	1x4 for Side Wall Fascia	72"
4	1x4 for Gable Trim	82-1/2"
12	2x3 for Gable Overhang	42-3/8"
14	Truss Gussets	7/16" 8" x 16"
2 ea.	Siding Panels	16" x 48"
2 ea.	Gable Siding	48" x 40" <i>angle cut</i>
4 ea.	Gable Siding	48" x 28" <i>angle cut</i>
12 ea.	Soffit Panels	48" x 7"
6 ea.	Soffit Fillers	48" x 3-1/2"

Qty.	<i>Material Shipped in 4' Extension Kit</i>	
2	2x4 for Collar Ties	82"
4	2x4 for Truss Rafters	80-1/2"
2	1x4 for Side Wall Fascia	48"
4	2x4 for Soffit Blocks	5" or longer
4	Truss Gussets	7/16" 10" x 24"
8	Truss Gussets	7/16" 12" x 24"
2 ea.	Soffit Panels	7" wide x 48"
4 ea.	H1 Metal Truss Hangers	

4 lbs.	10d	Sinkers
2 lbs.	6d	Galv.
10 lbs.	6d	Common
2 lbs.		Hanger Nails
100 ea.	1-1/2"	Exterior Screws
125 ea.	2-1/2"	Deck Screws
6 ea.	1"x4"	Metal Plates
14 ea.	H1	Metal Truss Hangers
2 ea.	1x6 Keystone	8-1/2"
2 ea.	Sheathing 7/16"	48" x 82-3/4"
2 ea.	Sheathing 7/16"	48" x 72"
2 ea.	Sheathing 7/16"	36-1/2" x 72"
2 ea.	Sheathing 7/16"	36-1/2" x 48"
2 ea.	Sheathing 7/16"	36-1/2" x 34-3/4"
2 ea.	Header Filler 7/16"	7-1/4" x 48"
2 ea.	Door Jamb	3/8" 5-3/8" x 48"
2 ea.	Door Jamb	3/8" 5-3/8" x 84"

Qty.	<i>Material Supplied by Local Supplier</i>	
44 pcs.	2x4	Pre-cut Wall Studs
12 pcs.	2x4 - 12'	Wall & Tie Plates
6 pcs.	2x4 - 12'	Treated Wall Plates
2 pcs.	2x8 - 10'	Door Header
22 pcs.	4x8 OSB	Sheathing
2 lbs.	16d Galv.	Nails