

## Obtaining a permit for your Best Barns shed or garage kits

*Do-it-Yourself kits from Best Barns are designed for use as storage buildings or garages only. Use for any other purposes is neither implied nor inferred.\**

Building code offices and HOA's may require additional documents to obtain a permit. The homeowner's first step is to contact their local code office and ask what is needed for the size of building to be purchased.

Typically, the necessary documentation may include some or all of the following.

- o Elevations showing at least two sides of structure.
- o Site plan showing existing structures and proposed build site.
- o Engineered drawings for truss system indicating snow and wind load ratings.\*\*
- o Cross sections of wall framing and foundation.
- o Tie down locations for high wind load areas.\*\*\*

Permit requirements vary based on location. Some areas may not require a permit at all. The documents provided by Best Barns are intended to help the homeowner with the permit process but do not guarantee a permit will be issued. It is the homeowner's responsibility to determine if a permit is required and submit the necessary documentation.

\*Any alteration to the construction of Best Barns sheds or garages may require the services of a civil engineer to meet local building codes. Best Barns cannot provide these additional services.

\*\* Engineered truss drawings stamped for your individual state can be obtained upon request. Some models do not have wind and snow load ratings. A deposit will be required if the shed or garage kit has not yet been purchased. Contact us directly at 800-245-1577 for further details.

\*\*\* Certain states such as Florida and California have stringent requirements for obtaining a permit. Depending on your location, a civil engineer's services may be required to provide necessary documents. These services are the homeowner's responsibility to obtain and are not included in the purchase of a shed or garage kit.

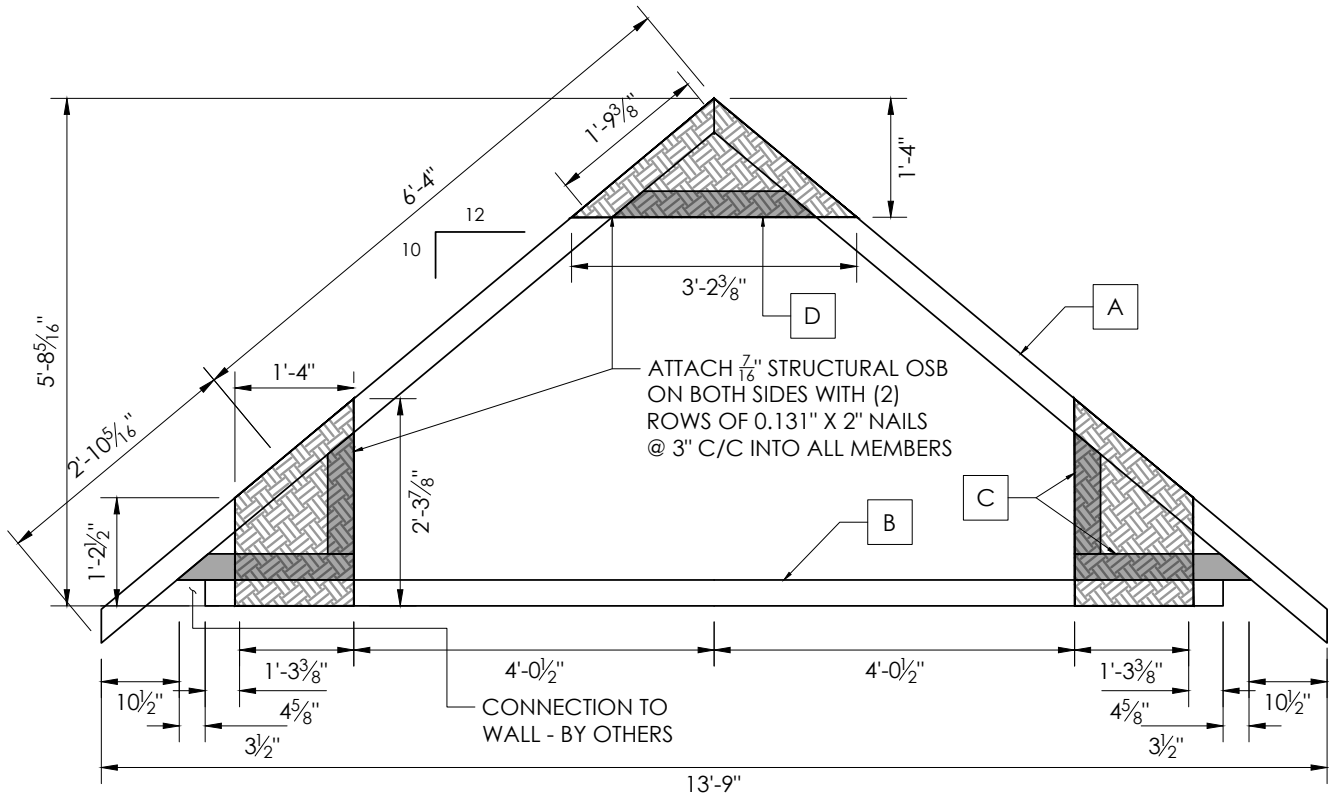

DESIGN BY / CHECKED BY:  
A.W. / O.A.

PROJECT NO.:  
476-23-0575

CUSTOMER:  
BEST BARN

TITLE:  
TIMBER TRUSS

STATE:  
XX - XXXXXXXXXXXX

DATE:  
01/24/2024

**DESIGN CRITERIA**

INTERNATIONAL BUILDING CODE  
IBC 2021, IBC 2018, IBC 2015 DESIGN CRITERIA

DEAD LOAD (D):

ROOF COLLATERAL DEAD LOAD 2.5 PSF

LIVE LOAD (Lr):

ROOF LIVE LOAD 20 PSF

ATTIC FLOOR LIVE LOAD (L)

FLOOR LIVE LOAD (BOTTOM CHORD) 10 PSF

SNOW LOAD (S):

GROUND SNOW LOAD 45 PSF  
SNOW LOAD IMPORTANCE FACTOR (Is) 1.0  
EXPOSURE FACTOR (Ce) 1.0  
THERMAL FACTOR (Ct) 1.2  
GOVERNING ROOF SNOW LOAD 30.65 PSF

UNBALANCED SNOW LOAD 45 PSF

WIND (W):

ANALYSIS PROCEDURE: ASCE 7-10 / ASCE 7-16  
BASIC WIND SPEED: 150 MPH  
EXPOSURE CATEGORY: C

LOAD COMBINATIONS:

- 1.0 D
- 1.0 D + 1.0 L
- 1.0 D + 1.0 (Lr or S)
- 1.0 D + 0.75 L + 0.75 (Lr or S)
- 1.0 D + (0.6 W)
- 1.0 D + 0.75 (1.0 W) + 0.75 L + 0.75 (Lr or S)
- 0.6 D + 1.0 W

**DESIGN DETAILS**

A - TOP CHORD	2X4
B - BOTTOM CHORD	2X4
C - WEB	2X4
D - COLLAR-TIE	2X4
SPACING	24" C/C
WOOD MATERIAL	SPF NO. 2
MAX. UNBRACED LENGTH OF TOP CHORD	5'-7 3/8"
DEAD LOAD DEFLECTION	L / 180
LIVE LOAD DEFLECTION	L / 240
DEAD + LIVE LOAD DEFLECTION	L / 180
UPLIFT REACTION AT CONN. TO WALL (LBF)	115
LATERAL REACTION AT CONN. TO WALL (LBF)	328
BEARING REACTION AT CONN. TO WALL (LBF)	621

**WOOD DESIGN NOTES:**

C <sub>D</sub> - LOAD DURATION FACTOR FOR WIND	1.6
C <sub>D</sub> - LOAD DURATION FACTOR FOR SNOW	1.15
C <sub>M</sub> - MOISTURE CONTENT	1.0
C <sub>t</sub> - TEMPERATURE FACTOR	1.0

- NOTES:
1. UNBALANCED SNOW LOADS HAVE BEEN CONSIDERED IN THE DESIGN.
  2. WIND LOADING IS BASED ON 3-S GUST ULTIMATE WIND SPEED, EXPOSURE C, PER ASCE 7.
  3. LOADS ARE BASED ON RISK CATEGORY II.
  4. SEE ADDITIONAL SHEETS FOR MEMBER CHECKS.

**CERTIFICATION EXPIRY:** XX/XX/XXXX  
**STAMP DATE EXPIRES:** XX/XX/XXXX  
**DATE SIGNED:** XX/XX/XXXX

# Hampton Elevation

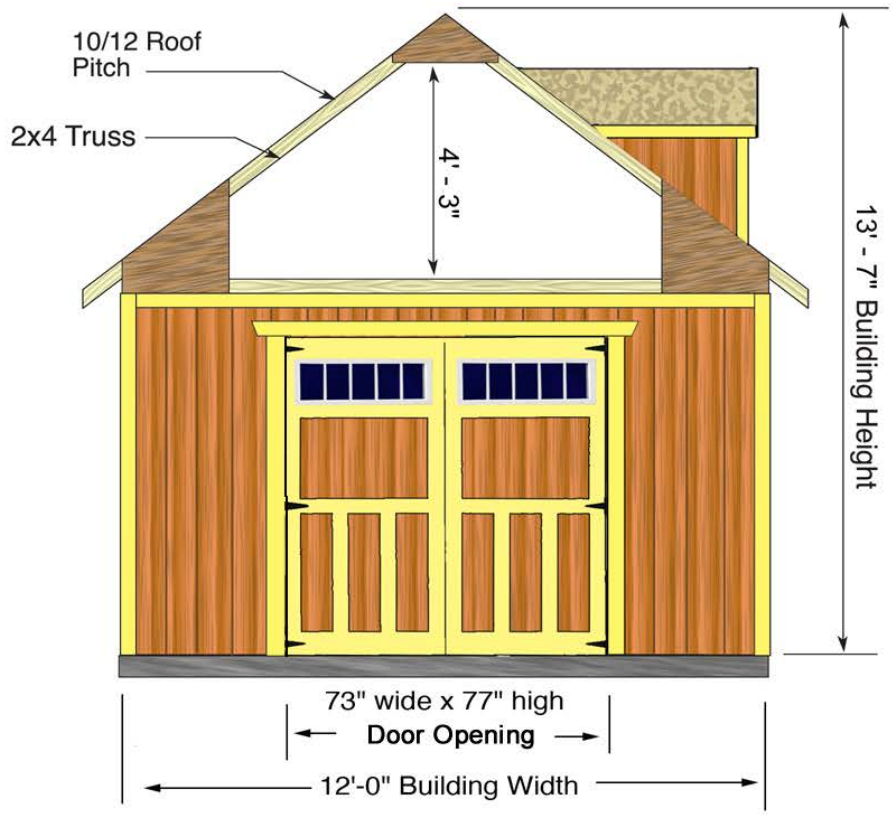
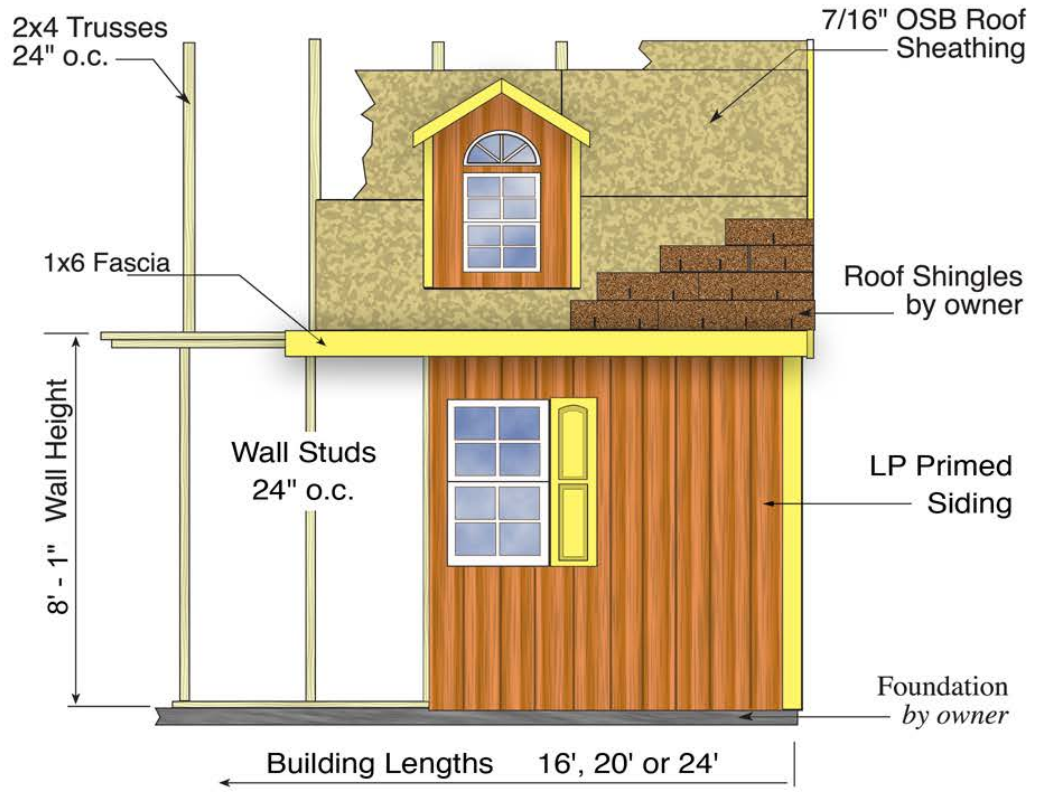

**Best Barns model:**

- Arlington
- Belmont
- Geneva
- Glenwood
- Hampton
- Springfield

12ft. wide x \_\_\_ft. long

Manufactured by:

RBS Holdings, Inc.

205 Arlington Drive

Greenville, PA 16125

phone: 800-245-1577

fax: 724-646-0772

**Truss & Wall  
Cross Section**

Top of wall inclusive of wall framing, loft floor and truss cross sections.

Drawing not to scale.

**Instructions:**

Homeowner may provide additional information as appropriate.

**Notes:**

Refer to installation manual for further detail.

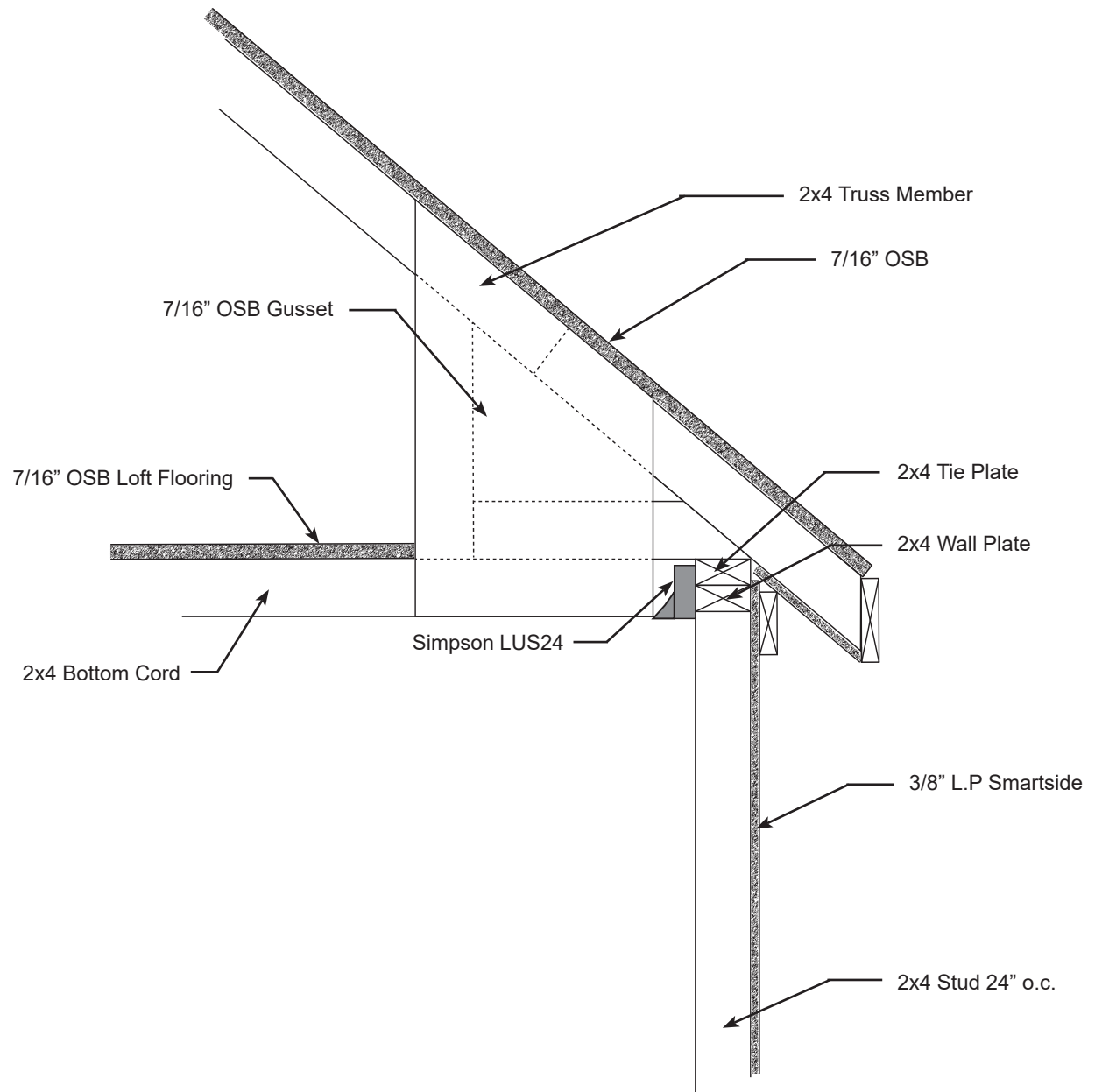

**Best Barns model:** \_\_\_\_\_  
\_\_\_\_ ft. wide x \_\_\_\_ ft. long

Manufactured by:  
RBS Holdings, LLC.  
205 Arlington Drive  
Greenville, PA 16125  
phone: 800-245-1577  
fax: 724-646-0772

### Common Foundation Cross Sections

This document illustrates common foundation types which can be used for construction of Best Barns 12 ft. wide structures. Alteration may be necessary to conform to homeowners intended use and or permitting requirements.

Drawings not to scale.

#### Instructions:

Check appropriate foundation cross section and provide specifications as necessary.

Homeowner may also design and draw in space provided for custom foundation type.

**Concrete Slab**

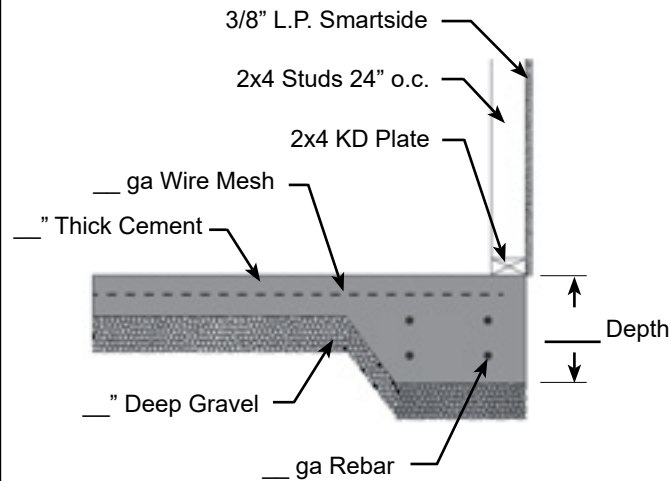

**Homeowner Design**

**Wood Floor**

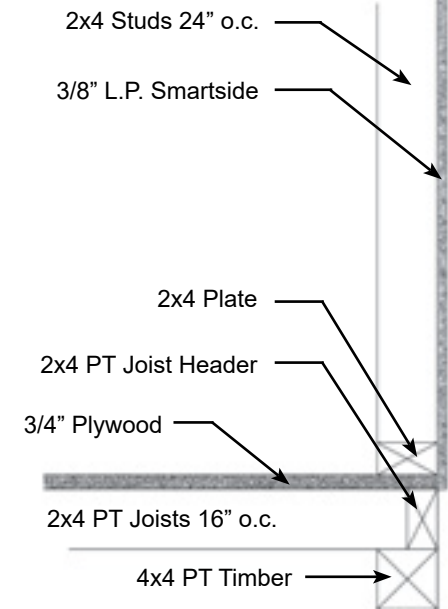

**Site Plan for:**

Manufactured by:  
RBS Holdings, Inc.  
205 Arlington Drive  
Greenville, PA 16125  
phone: 800-245-1577  
fax: 724-646-0772

**Instructions:**

Draw property line, existing structures and proposed placement of building.

Homeowner may also be required to show trees and shrubs. Check with HOA or permit office for requirements.

